



**TECPLOT 360**  
2009

## **Data Format Guide**

## COPYRIGHT NOTICE

Tecplot 360™ Data Format Guide is for use with Tecplot 360™ Version 2009.

Copyright © 1988-2009 Tecplot, Inc. All rights reserved worldwide. Except for personal use, this manual may not be reproduced, transmitted, transcribed, stored in a retrieval system, or translated in any form, in whole or in part, without the express written permission of Tecplot, Inc., 3535 Factoria Blvd, Ste. 550, Bellevue, WA 98006 U.S.A.

The software discussed in this documentation and the documentation itself are furnished under license for utilization and duplication *only* according to the license terms. The copyright for the software is held by Tecplot, Inc. Documentation is provided for information only. It is subject to change without notice. It should not be interpreted as a commitment by Tecplot, Inc. Tecplot, Inc. assumes no liability or responsibility for documentation errors or inaccuracies.

Tecplot, Inc.  
Post Office Box 52708  
Bellevue, WA 98015-2708 U.S.A.  
Tel: 1.800.763.7005 (within the U.S. or Canada), 00 1 (425) 653-1200 (internationally)  
email: sales@tecplot.com, support@tecplot.com  
Questions, comments or concerns regarding this document: documentation@tecplot.com  
For more information, visit <http://www.tecplot.com>

## THIRD PARTY SOFTWARE COPYRIGHT NOTICES

SciPy 2001-2009 Enthought, Inc. All Rights Reserved. NumPy 2005 NumPy Developers. All Rights Reserved. VisTools and VdmTools 1992-2009 Visual Kinematics, Inc. All Rights Reserved. NCSA HDF & HDF5 (Hierarchical Data Format) Software Library and Utilities Contributors: National Center for Supercomputing Applications (NCSA) at the University of Illinois, Fortner Software, Unidata Program Center (netCDF).

The Independent JPEG Group (JPEG), Jean-loup Gailly and Mark Adler (gzip), and Digital Equipment Corporation (DEC). Conditions of Redistribution: 1. Redistributions of source code must retain the above copyright notice, this list of conditions, and the following disclaimer. 2. Redistributions in binary form must reproduce the above copyright notice, this list of conditions, and the following disclaimer in the documentation and/or materials provided with the distribution. 3. In addition, redistributions of modified forms of the source or binary code must carry prominent notices stating that the original code was changed and the date of the change. 4. All publications or advertising materials mentioning features or use of this software are asked, but not required, to acknowledge that it was developed by The HDF Group and by the National Center for Supercomputing Applications at the University of Illinois at Urbana-Champaign and credit the contributors. 5. Neither the name of The HDF Group, the name of the University, nor the name of any Contributor may be used to endorse or promote products derived from this software without specific prior written permission from the University, THG, or the Contributor, respectively. DISCLAIMER: THIS SOFTWARE IS PROVIDED BY THE HDF GROUP (THG) AND THE CONTRIBUTORS "AS IS" WITH NO WARRANTY OF ANY KIND, EITHER EXPRESSED OR IMPLIED. In no event shall THG or the Contributors be liable for any damages suffered by the users arising out of the use of this software, even if advised of the possibility of such damage. Copyright © 1998-2006 The Board of Trustees of the University of Illinois, Copyright © 2006-2008 The HDF Group (THG). All Rights Reserved. PNG Reference Library Copyright © 1995, 1996 Guy Eric Schalnat, Group 42, Inc., Copyright © 1996, 1997 Andreas Dilger, Copyright © 1998, 1999 Glenn Randers-Pehrson. All Rights Reserved. Tcl 1989-1994 The Regents of the University of California. Copyright © 1994 The Australian National University. Copyright © 1994-1998 Sun Microsystems, Inc. Copyright © 1998-1999 Scriptics Corporation. All Rights Reserved. bmtopnm 1992 David W. Sanderson. All Rights Reserved. Netpbm 1988 Jef Poskanzer. All Rights Reserved. Mesa 1999-2003 Brian Paul. All Rights Reserved. W3C IPR 1995-1998 World Wide Web Consortium, (Massachusetts Institute of Technology, Institut National de Recherche en Informatique et en Automatique, Keio University). All Rights Reserved. Ppmtopict 1990 Ken Yap. All Rights Reserved. JPEG 1991-1998 Thomas G. Lane. All Rights Reserved.

## TRADEMARKS

Tecplot®, Tecplot 360™, the Tecplot 360™ logo, Preplot™, Enjoy the View™, and Framet™ are registered trademarks or trademarks of Tecplot, Inc. in the United States and other countries.

3D Systems is a registered trademark or trademark of 3D Systems Corporation in the U.S. and/or other countries. Macintosh OS is a registered trademark or trademark of Apple, Incorporated in the U.S. and/or other countries. Reflection-X is a registered trademark or trademark of Attachmate Corporation in the U.S. and/or other countries. EnSight is a registered trademark or trademark of Computation Engineering Internation (CEI), Incorporated in the U.S. and/or other countries. EDEM is a registered trademark or trademark of DEM Solutions Ltd in the U.S. and/or other countries. Exceed 3D, Hummingbird, and Exceed are registered trademarks or trademarks of Hummingbird Limited in the U.S. and/or other countries. Konqueror is a registered trademark or trademark of KDE e.v. in the U.S. and/or other countries. VIP and VDB are registered trademarks or trademarks of Halliburton in the U.S. and/or other countries. ECLIPSE FrontSim is a registered trademark or trademark of Schlumberger Information Solutions (SIS) in the U.S. and/or other countries. Debian is a registered trademark or trademark of Software in the Public Interest, Incorporated in the U.S. and/or other countries. X3D is a registered trademark or trademark of Web3D Consortium in the U.S. and/or other countries. X Window System is a registered trademark or trademark of X Consortium, Incorporated in the U.S. and/or other countries. ANSYS, Fluent and any and all ANSYS, Inc. brand, product, service and feature names, logos and slogans are registered trademarks or trademarks of ANSYS Incorporated or its subsidiaries in the U.S. and/or other countries. PAM-CRASH is a registered trademark or trademark of ESI Group in the U.S. and/or other countries. LS-DYNA is a registered trademark or trademark of Livermore Software Technology Corporation in the U.S. and/or other countries. MSC/NASTRAN is a registered trademark or trademark of MSC Software Corporation in the U.S. and/or other countries. NASTRAN is a registered trademark or trademark of National Aeronautics Space Administration in the U.S. and/or other countries. 3DSL is a registered trademark or trademark of StreamSim Technologies, Incorporated in the U.S. and/or other countries. SDRC/IDEAS Universal is a registered trademark or trademark of UGS PLM Solutions Incorporated or its subsidiaries in the U.S. and/or other countries. Star-CCM+ is a registered trademark or trademark of CD-adapco in the U.S. and/or other countries. Reprise License Manager is a registered trademark or trademark of Reprise Software, Inc. in the U.S. and/or other countries. Python is a registered trademark or trademark of Python Software Foundation in the U.S. and/or other countries. Abaqus, the 3DS logo, SIMULIA and CATIA are registered trademarks or trademarks of Dassault Systèmes or its subsidiaries in the U.S. and/or other countries. The Abaqus runtime libraries are a product of Dassault Systèmes Simulia Corp., Providence, RI, USA. © Dassault Systèmes, 2007 FLOW-3D is a registered trademark or trademark of Flow Science, Incorporated in the U.S. and/or other countries. Adobe, Flash, Flash Player, Premier and PostScript are registered trademarks or trademarks of Adobe Systems, Incorporated in the U.S. and/or other countries. AutoCAD and DXF are registered trademarks or trademarks of Autodesk, Incorporated in the U.S. and/or other countries. Ubuntu is a registered trademark or trademark of Canonical Limited in the U.S. and/or other countries. HP, LaserJet and PaintJet are registered trademarks or trademarks of Hewlett-Packard Development Company, Limited Partnership in the U.S. and/or other countries. IBM, RS/6000 and AIX are registered trademarks or trademarks of International Business Machines Corporation in the U.S. and/or other countries. Helvetica Font Family and Times Font Family are registered trademarks or trademarks of Linotype GmbH in the U.S. and/or other countries. Linux is a registered trademark or trademark of Linus Torvalds in the U.S. and/or other countries. ActiveX, Excel, Microsoft, Visual C++, Visual Studio, Windows, Windows Metafile, Windows XP, Windows Vista, Windows 2000 and PowerPoint are registered trademarks or trademarks of Microsoft Corporation in the U.S. and/or other countries. Firefox is a registered trademark or trademark of The Mozilla Foundation in the U.S. and/or other countries. Netscape is a registered trademark or trademark of Netscape Communications Corporation in the U.S. and/or other countries. SUSE is a registered trademark or trademark of Novell, Incorporated in the U.S. and/or other countries. Red Hat is a registered trademark or trademark of Red Hat, Incorporated in the U.S. and/or other countries. SPARC is a registered trademark or trademark of SPARC International, Incorporated in the U.S. and/or other countries. Products bearing SPARC trademarks are based on an architecture developed by Sun Microsystems, Inc. Solaris, Sun and SunRaster are registered trademarks or trademarks of Sun Microsystems, Incorporated in the U.S. and/or other countries. Courier is a registered trademark or trademark of Monotype Imaging Incorporated in the U.S. and/or other countries. UNIX and Motif are registered trademarks or trademarks of The Open Group in the U.S. and/or other countries. Qt is a registered trademark or trademark of Trolltech in the U.S. and/or other countries. Zlib is a registered trademark or trademark of Jean-loup Gailly and Mark Adler in the U.S. and/or other countries. OpenGL is a registered trademark or trademark of Silicon Graphics, Incorporated in the U.S. and/or other countries. JPEG is a registered trademark or trademark of Thomas G. Lane in the U.S. and/or other countries. All other product names mentioned herein are trademarks or registered trademarks of their respective owners.

## NOTICE TO U.S. GOVERNMENT END-USERS

Use, duplication, or disclosure by the U.S. Government is subject to restrictions as set forth in subparagraphs (a) through (d) of the Commercial Computer-Restricted Rights clause at FAR 52.227-19 when applicable, or in subparagraph (c)(1)(ii) of the Rights in Technical Data and Computer Software clause at DFARS 252.227-7013, and/or in similar or successor clauses in the DOD or NASA FAR Supplement. Contractor/manufacturer is Tecplot, Inc., 3535 Factoria Blvd, Ste. 550, Bellevue, WA 98006 U.S.A.

09-360-05-1

Rev 03/2009

---

# Table of Contents

---

<i>Chapter 1</i>	<i>Introduction</i> .....	7
	Creating Data Files for Both Tecplot 360 & Tecplot Focus .....	8
	Best Practices .....	8
	Recent Bug Updates .....	9
<i>Chapter 2</i>	<i>Data Structure</i> .....	11
	Ordered Data .....	12
	Finite Element Data .....	13
	<i>Line Data</i> .....	15
	<i>Surface Data</i> .....	15
	<i>Volume Data</i> .....	16
	<i>Finite Element Data Limitations</i> .....	16
	Variable Location (Cell-Centered or Nodal) .....	16
	Face Neighbors .....	17
	Working with Unorganized Datasets .....	18
	<i>Example - Triangulate a Dataset</i> .....	19
	<i>Example - Unorganized Three-Dimensional Volume</i> .....	20
	Time and Date Representation .....	21
<i>Chapter 3</i>	<i>Binary Data</i> .....	23
	Getting Started .....	23
	Viewing Your Output .....	24
	Binary Function Notes .....	25
	<i>Deprecated Binary Functions</i> .....	25
	<i>Character Strings in FORTRAN</i> .....	25

---

<i>Boolean Flags</i> .....	25
Binary Data File Function Calling Sequence .....	26
Writing to Multiple Binary Data Files .....	26
Linking with the TecIO Library .....	26
<i>UNIX/Linux/Macintosh</i> .....	27
<i>Windows</i> .....	27
<i>Notes for Windows Programmers using Fortran</i> .....	28
Binary Data File Function Reference .....	28
Defining Polyhedral and Polygonal Data .....	58
<i>Boundary Faces and Boundary Connections</i> .....	59
<i>FaceNodeCounts and FaceNodes</i> .....	60
<i>FaceRightElems and FaceLeftElems</i> .....	61
<i>FaceBoundaryConnectionElements and Zones</i> .....	63
<i>Partially Obscured Boundary Faces</i> .....	63
Examples .....	64
<i>Face Neighbors</i> .....	64
<i>Polygonal Example</i> .....	76
<i>Multiple Polyhedral Zones</i> .....	83
<i>Multiple Polygonal Zones</i> .....	103
<i>Polyhedral Example</i> .....	125
<i>IJ-ordered zone</i> .....	132
<i>Switching between two files</i> .....	137
<i>Text Example</i> .....	144
<i>Geometry Example</i> .....	147

## Chapter 4

<i>ASCII Data</i> .....	151
Preplot .....	151
Syntax Rules & Limits .....	151
ASCII File Structure .....	152
<i>File Header</i> .....	153
<i>Zone Record</i> .....	154
<i>Text Record</i> .....	167
<i>Geometry Record</i> .....	170
<i>Custom Labels Record</i> .....	173
<i>Data Set Auxiliary Data Record</i> .....	174
<i>Variable Auxiliary Data Record</i> .....	175
<i>ASCII Data File Parameter Assignment Values</i> .....	175
Ordered Data .....	176

---

	<i>I-Ordered Data</i> .....	176
	<i>IJ-Ordered Data</i> .....	176
	<i>IJK-Ordered Data</i> .....	177
	<i>Ordered Data Examples</i> .....	177
	Finite Element Data.....	185
	<i>Variable and Connectivity List Sharing</i> .....	187
	<i>Finite Element Data Set Examples</i> .....	189
	ASCII Data File Conversion to Binary .....	202
	<i>Preplot Options</i> .....	203
	<i>Preplot Examples</i> .....	203
<i>Chapter 5</i>	<i>Glossary</i> .....	205
<i>Appendix A</i>	<i>Binary Data File Format</i> .....	211



---

Tecplot 360 can read in data produced in many different formats, including in its own format. Refer to [Chapter 27 “Creating a Data Loader”](#) in the [ADK User’s Manual](#) for information on creating a data loader add-on for use with Tecplot 360.

This manual describes how to output your data into the Tecplot 360 data format. This Data Format Guide includes the following topics:

- [Chapter 2 “Data Structure”](#) Learn about the different types of data structure available in Tecplot 360 and how to use them.
- [Chapter 3 “Binary Data”](#) Refer to this chapter for details on outputting data into Tecplot 360’s binary file format (\*.plt). The chapter also includes instructions for linking with the TecIO library (a library of functions used to create binary data, included in your distribution). Refer to the final section in the chapter for detailed examples.
- [Chapter 4 “ASCII Data”](#) We strongly recommend that you create binary data files. However, we provide the ASCII data chapter to allow you to create simple data files.
- [Chapter 5 “Glossary”](#) Refer to the Glossary for the definitions of terms used throughout the manual.



Before continuing to either the Binary or ASCII chapter, please review this overview of [Best Practices](#).

## 1 - 1 Creating Data Files for Both Tecplot 360 & Tecplot Focus



For the purposes of this discussion, “polyhedral” refers to either polyhedral or polygonal zones.

If you intend to create data files that will load in both Tecplot 360 and Tecplot Focus, you need to be aware that polyhedral/polygonal zones are not supported in Tecplot Focus. If any of the zones in a given data file are polyhedral, you will not be able to load the data file into Tecplot Focus. To create data files that will load in both products, you must use either ordered zones or cell-based finite element zones (triangular, quadrilateral, tetrahedral or brick elements).

## 1 - 2 Best Practices

Users who wish to generate native Tecplot 360 data files automatically from applications such as complex flow solvers have a number of options for outputting data into Tecplot’s data format. This section outlines a few "best practices" for outputting your data into Tecplot 360 data format.

### 1. Create Binary Data Files instead of ASCII

All else being equal, binary data files are more efficient than ASCII files, in terms of disk space and time to first image. To create binary data files, you may use functions provided in the **tecIO** library included with your Tecplot distribution. To create ASCII files, you can write-out plain text using standard write statements.

There are some cases where ASCII files are preferred. Create ASCII files when:

- Your data files are small.
- Your application runs on a platform for which the **tecIO** library is not provided. Even if this is the case, please contact us at [support@tecplot.com](mailto:support@tecplot.com). There may be a way to resolve this issue.

### 2. Use Block Format instead of Point Format

Block format is by far the most efficient format when it comes to loading the file into Tecplot 360. If your data files are small and you can only obtain the data in a point-like format (for example, with a spreadsheet), then using point format is acceptable.



Binary files can only be written in block format. Point format is allowed for ASCII files, but running the preplot program will convert the data to block.

### 3. Use the Native Byte Ordering for the Target Machine

When you create binary data, you can elect to produce these files in either Motorola byte order or Intel byte order. Tecplot 360 automatically detects the byte order and loads both types. However, it is more efficient if you produce files using the byte order used on the platform where you run Tecplot 360. For example if you produce a binary file on an SGI platform and then transfer the data to a Windows® platform or Intel-based Linux box, you should set the flag to reverse the bytes when generating the binary data file. See the notes about this option in [Section B - 4 “Preplot”](#) in the [User’s Manual](#) for the Preplot flag.

### 4. Add Auxiliary data to Preset Variable Assignments in Tecplot 360

Zone Auxiliary data can be used to give Tecplot 360 hints about properties of your data. For example, it can be used to set the defaults for which variables to use for certain kinds of plots. Auxiliary data is supported by both binary and ASCII formats. Refer to [Section “TECAUXSTR112”](#) on page 28 or [Section 4- 3.6 “Data Set Auxiliary Data Record”](#) for information on working with auxiliary data in binary or ASCII data files, respectively. For a list of auxiliary data names, see [Chapter 12 “Auxiliary Data”](#) in the [ADK User’s Manual](#).

### 5. Data Sharing

Share variables whenever possible. Variable sharing is commonly used for the spatial variables (X, Y, and Z) when you have many sets of data that use the same basic grid. This saves disk space, as well as memory when the data is loaded into Tecplot 360. In addition, the benefits are compounded with scratch data derived from these variables because it is also shared within Tecplot 360. See also [Section “TECZNE112”](#) on page 53 (for binary data) or [Section 4- 5.1 “Variable and Connectivity List Sharing”](#) (for ASCII data).

### 6. Passive Variables

Tecplot 360 can manage many datasets at the same time. However, within a given dataset you must supply the same number of variables for each zone. In some cases you may have data where there are many variables and, for some of the zones some of those variables are not important. If that is the case, you can set selected variables in those zones to be passive. A passive variable is one that will always return the value zero if queried (e.g. in a probe) but will not involve itself in operations such as the calculations of the min and max range. This is very useful when calculating default contour levels.

## 1 - 3 Recent Bug Updates

FORTTRAN users may run into an “off by one” bug in the runtime version of the library that shipped with Tecplot 360 2008 (December 2007). You can download the corrected, precompiled libraries from <http://www.tecplot.com/support/tecio.aspx>.



Tecplot 360 accommodates two different types of data: [Ordered Data](#) and [Finite Element Data](#).

A connectivity list is used to define which nodes are included in each element of an ordered or cell-based finite element zone. You should know your zone type and the number of elements in each zone in order to create your connectivity list.

The number of nodes required for each element is implied by your zone type. For example, if you have a finite element quadrilateral zone, you will have four nodes defined for each element. Likewise, you must provide eight numbers for each cell in a BRICK zone, and three numbers for each element in a TRIANGLE zone. If you have a cell that has a smaller number of nodes than that required by your zone type, simply repeat a node number. For example, if you are working with a finite element quadrilateral zone and you would like to create a triangular element, simply repeat a node in the list (e.g., 1,4,5,5).

In the example below, the zone contains two quadrilateral elements. Therefore, the connectivity list must have eight values. The first four values define the nodes that form Element 1. Similarly, the second four values define the nodes that form Element 2.

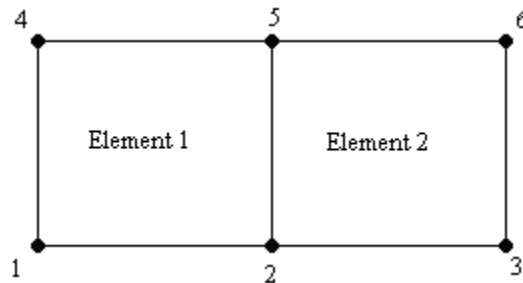

The connectivity list for this example would appear as follows:

```
ConnList[8] = {4,5,2,1,      /* nodes for Element 1 */
```

```
5,6,3,2); /* nodes for Element 2 */
```



It is important to provide your node list in either a clockwise or counter-clockwise order. Otherwise, your cell will twist, and the element produced will be misshapen.

## 2 - 1 Ordered Data

Ordered data is defined by one, two, or three-dimensional logical arrays, dimensioned by IMAX, JMAX, and KMAX. These arrays define the interconnections between nodes and cells. The variables can be either nodal or cell-centered. Nodal variables are stored at the nodes; cell-centered values are stored within the cells.

- **One-dimensional Ordered Data (I-ordered, J-ordered, or K-ordered)**

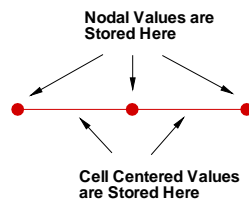

A single dimensional array where either IMAX, JMAX or KMAX is greater than or equal to one, and the others are equal to one. For nodal data, the number of stored values is equal to  $IMAX * JMAX * KMAX$ . For cell-centered I-ordered data (where IMAX is greater than one, and JMAX and KMAX are equal to one), the number of stored values is  $(IMAX-1)$  - similarly for J-ordered and K-ordered data.

- **Two-dimensional Ordered Data (IJ-ordered, JK-ordered, IK-ordered)**

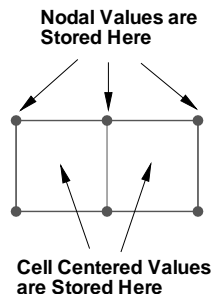

A two-dimensional array where two of the three dimensions (IMAX, JMAX, KMAX) are greater than one, and the other dimension is equal to one. For nodal data, the number of stored values is equal to  $IMAX * JMAX * KMAX$ . For cell-centered IJ-ordered data (where IMAX and JMAX are greater than one, and KMAX is equal to one), the number of stored values is  $(IMAX-1)(JMAX-1)$  - similarly for JK-ordered and IK-ordered data.

- **Three-dimensional Ordered Data (IJK-ordered)**

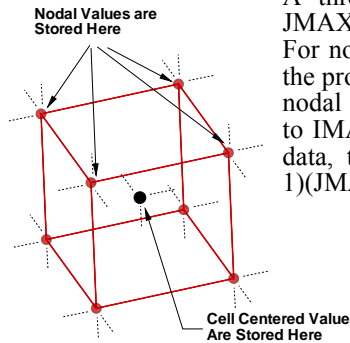

A three-dimensional array where all IMAX, JMAX and KMAX are each greater than one. For nodal ordered data, the number of nodes is the product of the I-, J-, and K-dimensions. For nodal data, the number of stored values is equal to  $IMAX * JMAX * KMAX$ . For cell-centered data, the number of stored values is  $(IMAX-1)(JMAX-1)(KMAX-1)$ .

## 2 - 2 Finite Element Data

While finite element data is usually associated with numerical analysis for modeling complex problems in 3D structures (heat transfer, fluid dynamics, and electromagnetics), it also provides an effective approach for organizing data points in or around complex geometrical shapes. For example, you may not have the same number of data points on different lines, there may be holes in the middle of the dataset, or the data points may be irregularly (randomly) positioned. For such difficult cases, you may be able to organize your data as a patchwork of elements. Each element can be independent of the other elements, so you can group your elements to fit complex boundaries and

leave voids within sets of elements. The figure below shows how finite element data can be used to model a complex boundary.

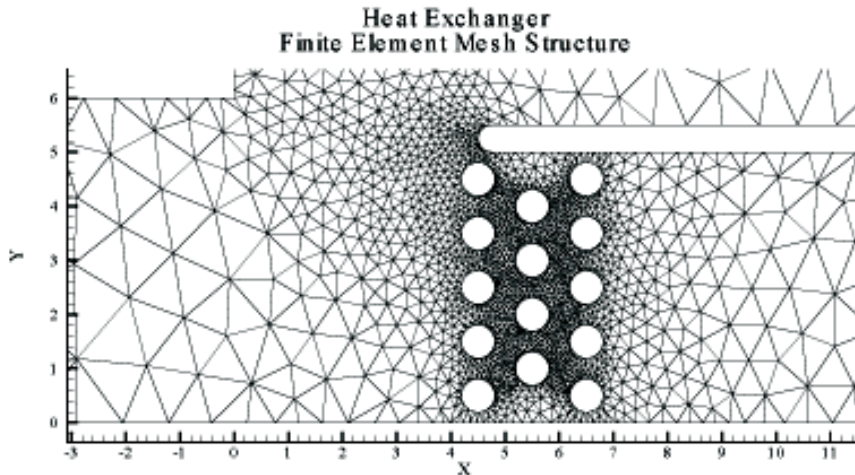
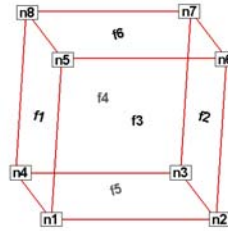
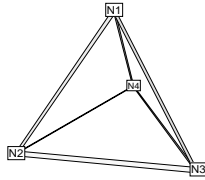

Figure 2-1. This figure shows finite element data used to model a complex boundary. This plot file, *feexchng.plt*, is located in your Tecplot 360 distribution under the *examples/2D* subdirectory.

Finite element data defines a set of points (nodes) and the connected elements of these points. The variables may be defined either at the nodes or at the cell (element) center. Finite element data can be divided into three types:

- **Line data** is a set of line segments defining a 2D or 3D line. Unlike I-ordered data, a single finite element line zone may consist of multiple disconnected sections. The values of the variables at each data point (node) are entered in the data file similarly to I-ordered data, where the nodes are numbered with the I-index. This data is followed by another set of data defining connections between nodes. This second section is often referred to as the connectivity list. All elements are lines consisting of two nodes, specified in the connectivity list.
- **Surface data** is a set of triangular, quadrilateral, or polygonal elements defining a 2D field or a 3D surface. When using polygonal elements, the number of sides may vary from element to element. In finite element surface data, you can choose (by zone) to arrange your data in three point (triangle), four point (quadrilateral), or variable-point (polygonal) elements. The number of points per node and their arrangement are determined by the element type of the zone. If a mixture of quadrilaterals and triangles is necessary, you may repeat a node in the quadrilateral element type to create a triangle, or you may use polygonal elements.

- **Volume data** is a set of tetrahedral, brick or polyhedral elements defining a 3D volume field. When using polyhedral elements, the number of sides may vary from element to element. Finite element volume cells may contain four points (tetrahedron), eight points (brick), or variable points (polyhedral). The figure below shows the arrangement of the nodes for tetrahedral and brick elements. The connectivity arrangement for polyhedral data is governed by the method in which the polyhedral facemap data is supplied.



*Tetrahedral connectivity arrangement*      *Brick connectivity arrangement*

*Figure 2-2. Connectivity arrangements for FE-volume datasets*

In the brick format, points may be repeated to achieve 4, 5, 6, or 7 point elements. For example, a connectivity list of “n1 n1 n1 n1 n5 n6 n7 n8” (where n1 is repeated four times) results in a quadrilateral-based pyramid element.

[Section 4 - 5 “Finite Element Data”](#) in the [Data Format Guide](#) provides detailed information about how to format your FE data in Tecplot’s data file format.

## 2- 2.1 Line Data

Unlike I-ordered data, a single finite element line zone may consist of multiple disconnected sections. The values of the variables at each data point (node) are entered in the data file similarly to I-ordered data, where the nodes are numbered with the I-index. This data is followed by another set of data defining connections between nodes. This second section is often referred to as the *connectivity list*. All elements are lines consisting of two nodes, specified in the connectivity list.

## 2- 2.2 Surface Data

In finite element surface data, you can choose (by zone) to arrange your data in three point (triangle), four point (quadrilateral), or variable-point (polygonal) elements. The number of points per node and their arrangement are determined by the element type of the zone. If a mixture of quadrilaterals and triangles is necessary, you may repeat a node in the quadrilateral element type to create a triangle or you may use polygonal elements.

### 2- 2.3 Volume Data

Finite element volume cells may contain four points (tetrahedron), eight points (brick) or variable points (polyhedral). The figure below shows the arrangement of the nodes for tetrahedral and brick elements. The connectivity arrangement for polyhedral data is governed by the method in which the polyhedral facemap data is supplied.

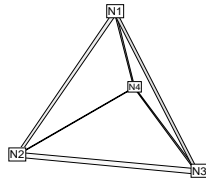

*Tetrahedral connectivity arrangement*

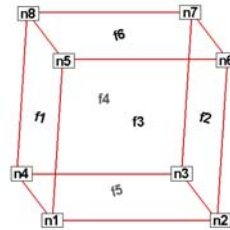

*Brick connectivity arrangement*

*Figure 2-3. Connectivity arrangements for FE-volume datasets*

In the brick format, points may be repeated to achieve 4, 5, 6, or 7 point elements. For example, a connectivity list of “n1 n1 n1 n1 n5 n6 n7 n8” (where n1 is repeated four times) results in a quadrilateral-based pyramid element.

### 2- 2.4 Finite Element Data Limitations

Working with finite element data has some limitations:

- XY-plots of finite element data treat the data as I-ordered; that is, the connectivity list is ignored. Only nodes are plotted, not elements, and the nodes are plotted in the order in which they appear in the data file.
- Index skipping in vector and scatter plots treats finite element data as I-ordered; the connectivity list is ignored. Nodes are skipped according to their order in the data file.

## 2 - 3 Variable Location (Cell-Centered or Nodal)

Add-ons must be aware of the data value location. Data values can be stored at the nodes or at the cell centers.

- For finite element meshes, cell-centers are the centers (centroids) of elements.
- For many types of plots, cell-centered values are interpolated to the nodes internally.

Because the offset into the data is different for nodal values and cell-centered values, you must know ahead of time how the values are stored when accessing data.

You can determine the value location by calling `TecUtilDataValueGetLocation`.

Example:

```
ValueLocation_e ValueLocation;
ValueLocation = TecUtilDataValueGetLocation(Zone, Var);
Switch (ValueLocation)
{case ValueLocation_Nodal :
  {
    ...data is stored at the nodes.
    ...Access the data accordingly.
  }
case ValueLocation_CellCentered :
  {
    ...data is stored at the cell centers.
    ...Access the data accordingly.
  }
}
```

## 2 - 4 Face Neighbors

A cell is considered a neighbor if one of its faces shares all nodes in common with the selected cell, or if it is identified as a neighbor by face neighbor data in the dataset. The face numbers for cells in the various zone types are defined below.

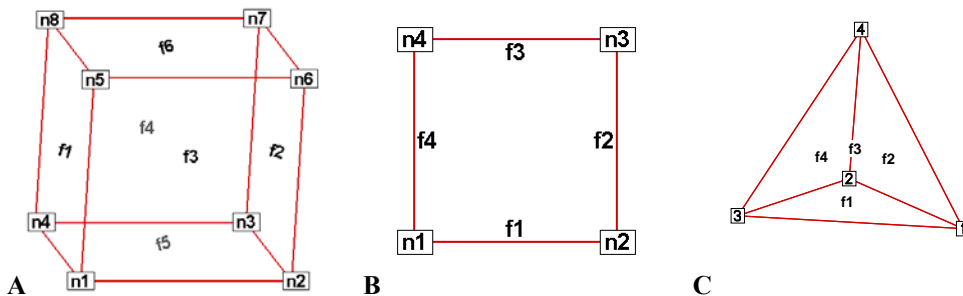

*Figure 2-1.* **A:** Example of node and face neighbors for an FE-brick cell or IJK-ordered cell. **B:** Example of node and face numbering for an IJ-ordered/ FE-quadrilateral cell. **C:** Example of tetrahedron face neighbors.

The implicit connections between elements in a zone may be overridden, or connections between cells in adjacent zones established by specifying face neighbor criteria in the data file. Refer to [Section “TECFACE112”](#) on page 33 of the [Data Format Guide](#) for additional information.

## 2 - 5 Working with Unorganized Datasets

Unorganized datasets are loaded as a single I-ordered zone and will be displayed in XY Mode, by default. An I-ordered zone is irregular if it is known to have more than one dependent variable. An I-ordered dataset with one dependent variable (i.e. an XY or polar line) is NOT an irregular zone.

To check for irregular data, you can go to the **Data>Dataset Info** dialog (accessed via the **Data** menu). The values assigned to: IMax, JMax, and KMax are displayed in the lower left quadrant of that dialog. If IMax is greater than 1, and JMax and KMax are equal to 1, then your data is irregular.

It is also easy to tell if you have irregular data by looking at the plot. If you are looking at irregular data with the Mesh layer turned on, the datapoints will be connected by lines in the order the points appear in the dataset.

There are several ways to organize your dataset.

1. Manually order the data file using a text editor.



Use the “Label Points and Cells” feature from the **Plot** menu to see if your dataset can be easily corrected using a text editor by correcting the values for I, J, and/or K.

2. Use the **Data>Triangulate** feature (2D only). See [Section 21 - 11 “Irregular Data Point Triangulation”](#).
3. Use one of the **Data>Interpolation** options. See [Section 21 - 10 “Data Interpolation”](#).
4. If you have multiple zones of irregular data that you would like to combine into one finite element zone, use the **Create Zone>Create Zone From Polylines** from the **Data** menu. Refer to [Section 21- 6.6 “FE Surface Zone Creation \(from Polylines\)”](#) for more information.
5. Special Cases (use when interpolation results appear skewed):
  - Well data - If points are closely positioned along the depth axis and far apart in physical space, use the **Tetra Grid** add-on to create a new zone with all points connected into 3D zones. See [Section 33- 3.20 “Tetra Grid”](#).
  - Fluid Measurements - When measurements are taken of fluid properties or containments, and interpolating to a rectangular zone does not yield good results, use the **Prism Grid** add-on to create a 3D volume zone. See [Section 33- 3.14 “Prism Grid”](#).

### 2- 5.1 Example - Triangulate a Dataset

One common source of finite-element surface data is the triangulation option. If you have 2D data without a mesh structure, it is probably simplest to enter your data points as an I-ordered dataset,

then use the triangulation feature to create a finite-element dataset. You can then edit the file—particularly the connectivity list—to obtain the set of elements you want, rather than having to create the entire connectivity list by hand.

We can triangulate a dataset as follows:

1. Create a simple ordered data file, as follows:

```
VARIABLES = "X", "Y", "P", "T"
0.0 1.0 100.0 1.6
1.0 1.0 150.0 1.5
3.0 1.0 300.0 2.0
0.0 0.0 50.0 1.0
1.0 0.0 100.0 1.4
3.0 0.0 200.0 2.2
4.0 0.0 400.0 3.0
2.0 2.0 280.0 1.9
```

2. Save the file, with extension \*.dat
3. Load the data file and switch the plot type to **2D Cartesian**.
4. From the **Data** menu, choose “Triangulate”.
5. Select the simple ordered zone as the source zone, and select [Compute].

### Irregular Data Point Triangulation

[Figure 2-2](#) shows a plot of the resulting data. With triangulation, we obtain more elements (seven) than when we created the dataset by hand (four), and the elements are triangles rather than quadrilaterals.

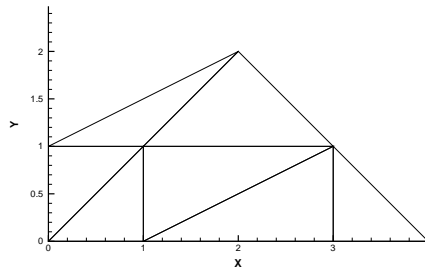

Figure 2-2. Triangulated data from [Table 4 - 2 of the Data Format Guide](#).

## 2- 5.2 Example - Unorganized Three-Dimensional Volume

To use 3D volume irregular data in field plots, you must interpolate the data onto a regular, IJK-ordered zone. (Tecplot 360 does not have a 3D equivalent for triangulation.) To interpolate your data, perform the following steps:

1. Place your 3D volume irregular data into an I-ordered zone in a data file.

2. Read in your data file and create a 3D scatter plot.
3. From the **Data** menu, choose **Create Zone>Rectangular**. (**Circular** will also work.)
4. In the **Create Rectangular Zone** dialog, enter the I-, J-, and K-dimensions for the new zone; at a minimum, you should enter 10 for each dimension. The higher the dimensions, the finer the interpolation grid, but the longer the interpolating and plotting time.
5. Enter the minimum and maximum X, Y, and Z values for the new zone. The default values are the minimums and maximums of the current (irregular) dataset.
6. Click [Create] to create the new zone, and [Close] to dismiss the dialog.
7. From the **Data** menu, choose **Interpolate>Kriging**. (**Linear** or **Inverse distance Interpolation** also work.)
8. In the **Kriging** dialog, choose the irregular data zone as the source zone, and the newly created IJK-ordered zone as the destination zone. Set any other kriging parameters as desired (see [Section 21- 10.3 “Kriging”](#) for details).
9. Select the [Compute] button to perform the kriging.

Once the interpolation is complete, you can plot the new IJK-ordered zone as any other 3D volume zone. You may plot iso-surfaces, volume streamtraces, and so forth. At this point, you may want to deactivate or delete the original irregular zone so as not to conflict with plots of the new zone.

[Figure 2-3](#) shows an example of irregular data interpolated into an IJK-ordered zone, with iso-surfaces plotted on the resultant zone.

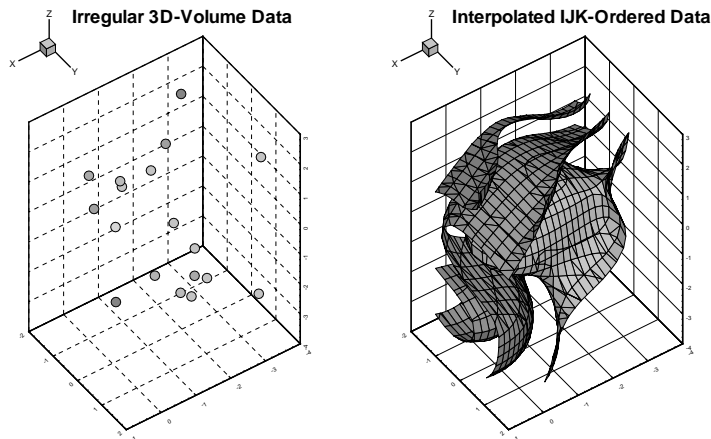

*Figure 2-3.* Irregular data interpolated into an IJK-ordered zone.

---

## 2 - 6 Time and Date Representation

Tecplot 360 uses floating point numbers to represent times and dates. The integer portion represents the number of days since December 30, 1899. The decimal portion represents a fractional portion of a day. The table below illustrates some examples of this method.

Date	Time	Floating Point Number
1900-01-01	00:00:00	2.0
1900-01-01	12:00:00	2.5
2008-07-31	00:00:00	39660.0
2008-07-31	12:00:00	39660.5
2008-07-31	12:01:00	39660.5006944444
2008-07-31	13:00:00	39660.5416666667

Tecplot 360 supports dates from 1800-01-01 through 9999-12-31.

This formatting matches the representation method used by Microsoft Excel, enabling you to load time/date data easily from Excel into Tecplot 360. However, because Excel software's original formatting incorrectly calculated 1900 as a leap year, only dates from Mar 1, 1900 forward will import correctly into Tecplot 360.



---

This chapter is intended for experienced programmers who need to create Tecplot binary data files directly. Support for topics discussed in this chapter is limited to general questions about writing Tecplot binary files. It is beyond the scope of our Technical Support to offer programming advice and to debug programs. For additional help, visit [www.tecplottalk.com](http://www.tecplottalk.com).

Data files for Tecplot 360 are commonly created as output from an application program. These files are most often in ASCII format, and are then converted to a binary format with Preplot (see [Section 4 - 1 “Preplot”](#) for additional information).

To output your data into Tecplot’s binary format, you may use the static library provided with your Tecplot 360 installation or you may write your own binary functions. If you wish to write your own functions, refer to [Appendix A “Binary Data File Format”](#) for details on the structure of Tecplot’s binary file format. If you wish to link with the library provided by Tecplot, begin with [Section 3 - 1 “Getting Started”](#) and use [Appendix A “Binary Data File Format”](#) for reference.



You can find source files for most of the examples in this chapter in the separately downloadable TecIO package available at [www.tecplot.com](http://www.tecplot.com).

## 3 - 1 Getting Started

Your Tecplot 360 distribution includes a library of utility functions that you can link with your application to create binary data files directly, bypassing the use of ASCII files. This allows for fewer files to manage, conserves disk space, and saves the time required to convert the files.

On UNIX®, Linux®, Macintosh® platforms, the utility functions discussed in [Section 3 - 7 “Binary Data File Function Reference”](#) are available in the library archive `tecio.a` which is located in the `lib` directory below the `$TEC_360_2009` Directory. On Windows platforms, this library is called `TECIO.lib` and is located in the `bin` sub-directory of your installation.

When preparing to output your data in Tecplot’s binary format using the `tecio` library, we recommend you perform the following steps:

1. Review [Section 3 - 4 “Binary Data File Function Calling Sequence”](#) and [Section 3 - 5 “Writing to Multiple Binary Data Files”](#) in this manual.

2. Review the example files downloadable separately in the TecIO package, in the *util/tecioexamples* folder. The example programs demonstrate the use of the `TecIO` utility functions and are provided in both FORTRAN and C/C++:
  - `simtest.f`, `simtest.f90`, `simtest.c` - These files demonstrate simple use of the TecIO utility functions.
  - `comtest.f`, `comtest.f90`, `comtest.c` - These files demonstrate complex use of TecIO utility functions, such as multiple file generation and transient data.Numerous additional, more modern examples included in the TecIO package target specific actions, like writing polyhedral data. Review these examples for additional guidance.
3. Follow the instructions in [Section 3 - 6 “Linking with the TecIO Library”](#) for information on linking with the `TecIO` library.
4. Begin developing your code.

## 3 - 2 Viewing Your Output

You may load your binary files in Tecplot using the Tecplot Data loader (refer to [Section 4 - 15 “Tecplot-Format Loader”](#) for details). In addition, you may view information about your data file using any of the following techniques:

- [Pltview](#) - Pltview is a command line utility that displays the header information for your file. It is installed in `$TEC_360_2009/bin`. Refer to [Section B - 6 “Pltview”](#) on page 673 in the [User’s Manual](#) for details on working with pltview.
- [View Binary](#) - The **ViewBinary** add-on allows you to view the information in a Tecplot binary data (`.plt`) file. It is included in a standard Tecplot distribution. Refer to [Section 33- 3.22 “View Binary”](#) on page 655 in the [User’s Manual](#) for details.
- [Dataset Information](#) dialog - You may use the **Data Set Information** dialog (accessed via the **Data** menu) to display information about your plt file (once it is loaded into Tecplot). Refer to this dialog for a list of the zones, variables, variable ranges, auxiliary data and more. Refer to [Section 5 - 4 “Dataset Information”](#) on page 165 in the [User’s Manual](#) for details.
- [Data Spreadsheet](#) - Use the Data Spreadsheet to view a table of every variable value in your file. Refer to [Section 21 - 12 “Data Spreadsheet”](#) in the [User’s Manual](#) for details.

## 3 - 3 Binary Function Notes



The *.plt* file that you create will be compatible with the version of Tecplot tied to the version of the TecIO library that you use. For example, if you use the TecIO library that was bundled with Tecplot 360 Version 2006, your files can be loaded with Tecplot 360 Version 2006 and newer.

This is independent of the version number used for the binary functions (for example, the 112 in TECZNE112). For example, even if you use 110 functions with the version of the TecIO library included with this distribution, your *plt* file will be compatible with this version of Tecplot 360 and newer.

### 3- 3.1 Deprecated Binary Functions

Functions that end in 111 or less are deprecated. We recommend you use the 112 binary function family. In order to use the 112 family of functions, use the TecIO library included in your Tecplot 360 2009 distribution. If you update existing binary function calls to use version 112, you will need to update all of your binary calls.

The following functions were altered during the upgrade to the 111 family:

- **TECINI** - The FileType parameter was added **TECINI**. Files from previous versions are of type "FULL". See [Section "TECINI112"](#) on page 42 for additional information.
- **TECZNE** - Three parameters, TotalNumFaceNodes, NumConnectedBoundaryFaces and TotalNumBoundaryConnections were added to TECZNE111. Refer to [Section "TECZNE112"](#) on page 53 for details.

### 3- 3.2 Character Strings in FORTRAN

All character string parameters in FORTRAN must terminate with a null character. This is done by concatenating `char(0)` to the end of a character string.

For example, to send the character string "Hi Mom" to a function called **A**, use the following syntax:

```
I=A("Hi Mom"//char(0))
```

### 3- 3.3 Boolean Flags

Integer parameters identified as "flags" indicate boolean values. Pass 1 for true, and 0 for false.

### 3 - 4 Binary Data File Function Calling Sequence

For a given file, the binary data file functions must be called in a specific order.

The order is as follows:

[TECFOREIGN112](#) (*Optional*)

[TECINI112](#)

For each call to [TECINI112](#), use one or more of the following commands:

[TECAUXSTR112](#) (*Optional*)

[TECVAUXSTR112](#) (*Optional*)

[TECZNE112](#) (*One or more to create multiple zones*)

For each call to [TECZNE112](#), use one or more of these commands:

[TECDAT112](#) (*One or more to fill each zone*)

[TECNOD112](#) (*One for each finite element zone*)

[TECFACE112](#) (*One for each zone with face connections*)

[TECPOLY112](#) (*Optional - use for polyhedral data*)

[TECZAUXSTR112](#) (*Optional*)

[TECLAB112](#) (*Optional*)

[TECGEO112](#) (*Optional*)

[TECTXT112](#) (*Optional*)

[TECFIL112](#) (*Optional - use if you are switching between files*)

[TECUSR112](#) (*Optional*)

[TECEND112](#)

[Section 3 - 5 “Writing to Multiple Binary Data Files”](#) explains how you can use the [TECFIL112](#) function along with the above functions to write to multiple files simultaneously.

### 3 - 5 Writing to Multiple Binary Data Files

Each time [TECINI112](#) is called it sets up a new file “context.” For each file context you must maintain the order of the calls as described in the previous section. The [TECFIL112](#) function is used to switch between file contexts. Up to 10 files can be written to at a time. [TECFIL112](#) can be called almost anywhere after [TECINI112](#) has been called. The only parameter to [TECFIL112](#), an integer, *n*, shifts the file context to the *n*th open file. The files are numbered relative to the order of the calls to [TECINI112](#).

### 3 - 6 Linking with the TecIO Library

To output data in Tecplot’s binary format, you may write your own functions or use the library provided with your installation. On Windows platforms, `tecio.lib` is installed in the bin directory of

your Tecplot 360 installation.<sup>1</sup> On UNIX, Linux, and Macintosh platforms, `tecio.a` is installed in the `lib` directory of your Tecplot 360 installation. Follow the instructions below to link with Tecplot's library.



The `*.plt` file that you create will be compatible with the version of Tecplot tied to the version of the TecIO library that you use. For example, if you use the TecIO library that was bundled with Tecplot 360 Version 2006, your files can be loaded with Tecplot 360 Version 2006 and newer.

This is independent of the version number used for the binary functions (for example, the 112 in `TECZNE112`). For example, even if you use 110 functions with the version of the TecIO library included with this distribution, your `plt` file will be compatible with this version of Tecplot and newer.

### 3- 6.1 UNIX/Linux/Macintosh

To link with the `tecio.a` library, follow these steps.

1. Download `tecio.a` from <http://download.tecplot.com>. Place this file in a reasonable location, such as `$TEC_360_2009/util`.
2. Link to the `tecio.a` library by adding the full path to `tecio.a` to the link command.
3. If you are using Fortran or C on a Linux or Mac platform, you may need to link to the `libstdc++` library as well. To link with `libstdc++`, add the following to your link command:

```
-lstdc++
```



Some `f90` compilers do not accept the `f90` file extension.

### 3- 6.2 Windows

Only the `.c` and `.f90` source files are used on Windows operating systems.

To link with the `tecio` library, perform the following steps:

1. On Windows platforms, you will need to include `tecio.dll` in any distributions you create. `Tecio.dll` is provided in `$TEC_360_2009/bin` along with `tecio.lib`.

1. Create a development project
2. List `$(TEC_360_2009)/bin/tecio.lib` as an additional dependency. In Visual Studio 2005, this is accomplished via: **Configuration Properties>Linker>Input** in the **Project Properties** dialog.
3. Include the `tecio` header files (`TECIO.h` and `TECXXX.h`), located in `TEC_360_2009/include`.

### 3- 6.3 Notes for Windows Programmers using Fortran

Files `tecio.f90` and `tecio.for`, located in the `include` folder in your installation, contain both Fortran-90 interfaces for all `tecio` routines and several compiler-specific directives (the `!MS$ATTRIBUTES` lines). These direct Visual Fortran to use `STDCALL` calling conventions with by-reference parameter passing. While `tecio.f90` is free-formatted, `tecio.for` contains the traditional column-based formatting. Include the appropriate file in any of your subroutines that call `tecio` routines. Both files were developed for Intel Visual Fortran version 9.

Users of other compilers may need to adjust the Fortran settings or add other compiler directives to achieve the same effect. In particular, Fortran strings must be NULL-terminated and passed without a length argument.

## 3 - 7 Binary Data File Function Reference

This section describes each of the `tecio` functions in detail.

---

### TECAUXSTR112

---

Writes auxiliary data for the data set to the data file. The function may be called at any time between [TECINI112](#) and [TECEND112](#). Auxiliary data may be used by text, macros, equations (if it is numeric) and add-ons. It may be viewed directly in the *Aux Data* page of the **Data Set Information** dialog (accessed via the **Data** menu).

#### *FORTRAN Syntax:*

```
INTEGER*4 FUNCTION TECAUXSTR112 (Name,  
&                               Value)  
CHARACTER* (*) Name  
CHARACTER* (*) Value
```

#### *C Syntax:*

```
#include TECIO.h  
INTEGER4 TECAUXSTR112 ( char *Name,  
                       char *Value)
```

**Return Value:**

0 if successful, -1 if unsuccessful.

**Parameters:**

Parameter	Description
Name	The name of the auxiliary data. If this duplicates an existing name, the value will overwrite the existing value. It must be a null-terminated character string and cannot contain spaces.
Value	The value to assign to the named auxiliary data. It must be a null-terminated character string.

**Example**

For example, to set an Auxiliary Variable called DeformationValue to 0.98:

```
char DeformationValue[128];
strcpy(DeformationValue,"0.98");

TECAUXSTR112("DeformationValue",
             DeformationValue);
```

When the data file is loaded into Tecplot, "Deformation Value" will appear on the *Aux Page* of the **Data Set Information** dialog when "for Data Set" is selected in *Show Auxiliary Data* menu.

**TECDAT112**

Writes an array of data to the data file. Data should not be passed for variables that have been indicated as passive or shared (via [TECZNE112](#)).

**TECDAT112** allows you to write your data in a piecemeal fashion in case it is not contained in one contiguous block in your program. **TECDAT112** must be called enough times to ensure that the correct number of values are written for each zone and that the aggregate order for the data is correct.

In the above summary, NumVars is based on the number of variable names supplied in a previous call to [TECINI112](#).

**FORTRAN Syntax:**

```
INTEGER*4 FUNCTION          TECDAT112 ( N,
&                             Data,
&                             IsDouble)
INTEGER*4                   N
REAL or DOUBLE PRECISION   Data (1)
```

INTEGER\*4

IsDouble

***C Syntax:***

```
#include TECIO.h
INTEGER4 TECDAT112 (INTEGER4 *N,
                    void *Data,
                    INTEGER4 *IsDouble);
```

***Return Value:***

0 if successful, -1 if unsuccessful.

**Parameters:**

Parameter	Description
N	Pointer to an integer value specifying number of values to write.
Data	Array of single or double precision data values. Refer to <a href="#">Table 3 - 1</a> for a description of how to arrange your data.
IsDouble	Pointer to the integer flag stating whether the array Data is single (0) or double (1) precision.

**Data Arrangement**

The following table describes the order the data must be supplied given different zone types. IsBlock and VarLocation are parameters supplied to [TECZNE112](#). The value of IsBlock should always be 1, since binary data must be written in block format:

Zone Type	Var. Location	IsBlock	Number of Values	Order
Ordered	Nodal	1	IMax* JMax* KMax* NumVars	I varies fastest, then J, then K, then Vars. That is, the numbers should be supplied in the following order: for (Var=1;Var<=NumVars;Var++) for (K=1;K<=KMax;K++) for (J=1;J<=JMax;J++) for (I=1;I<=IMax;I++) Data[I, J, K, Var] = value;
Ordered	Cell Centered	1	(IMax-1)* (JMax-1)* (KMax-1)* NumVars	I varies fastest, then J, then K, then Vars. That is, the numbers should be supplied in the following order: for (Var=1;Var<=NumVars;Var++) for (K=1;K<=(KMax-1);K++) for (J=1;J<=(JMax-1);J++) for (I=1;I<=(IMax-1);I++) Data[I, J, K, Var] = value;

**Table 3 - 1: Data Arrangement**

Zone Type	Var. Location	IsBlock	Number of Values	Order
Finite element	Nodal	1	IMax (i.e. NumNodes) * NumVars	N varies fastest, then Vars. That is, the numbers should be supplied in the following order: for (Var=1;Var<=NumVars;Var++) for (N=1;N<=NumNodes;N++) Data[N, Var] = value;
Finite element	Cell Centered	1	JMax (i.e. NumElements) * NumVars	E varies fastest, then Var. That is, the numbers should be supplied in the following order: for (Var=1;Var<=NumVars;Var++) for (E=1;E<=NumElements;E++) Data[E, Var] = value;

**Table 3 - 1: Data Arrangement**

### *Example*

Refer to the following examples in [Section 3 - 9 “Examples”](#) for examples using `TECDAT112`:

- [Section 3- 9.1 “Face Neighbors”](#)
- [Section 3- 9.2 “Polygonal Example”](#)
- [Section 3- 9.3 “Multiple Polyhedral Zones”](#)
- [Section 3- 9.4 “Multiple Polygonal Zones”](#)
- [Section 3- 9.5 “Polyhedral Example”](#)
- [Section 3- 9.6 “IJ-ordered zone”](#)

---

## TECEND112

---

*Must* be called to close out the current data file. There must be one call to `TECEND112` for each [TECINI112](#).

### *FORTRAN Syntax:*

```
INTEGER*4 FUNCTION TECEND112 ()
```

### *C Syntax:*

```
#include TECIO.h
INTEGER4 TECEND112 ();
```

---

**Return Value:**

0 if successful, -1 if unsuccessful.

**Parameters:**

None.

---

**TECFACE112**

---

Writes face connections for the current zone to the file. Face Neighbor Connections are used for ordered or cell-based finite element zones to specify connections that are not explicitly defined by the connectivity list or ordered zone structure. You may use face neighbors to specify connections between zones (global connections) or connections within zones (local connections). Face neighbor connections are used by Tecplot when deriving variables or drawing contour lines. Specifying face neighbors, typically leads to smoother connections. NOTE: face neighbors have expensive performance implications. Use face neighbors only to manually specify connections that are not defined via the connectivity list.

This function must be called after [TECNOD112](#), and may only be called if a non-zero value of *NumFaceConnections* was used in the previous call to [TECZNE112](#).

**FORTRAN Syntax:**

```
INTEGER*4 FUNCTION TECFACE112(FaceConnections)
INTEGER*4          FACECONNECTIONS (*)
```

**C Syntax:**

```
#include TECIO.h
INTEGER4 TECFACE112(INTEGER4 *FaceConnections);
```

**Return Value:**

0 if successful, -1 if unsuccessful.

**Parameters:**

Parameter	Description
<b>FaceConnections</b>	The array that specifies the face connections. The array must have L values, where L is the sum of the number of values for each face neighbor connection in the data file. The number of values in a face neighbor connection is dependent upon the <b>FaceNeighborMode</b> parameter (set via <a href="#">TECZNE112</a> ) and is described in the following table.

FaceNeighbor Mode	Number of values	Data
LocalOneToOne	3	cz1 ,fz,cz2
LocalOneToMany	nz+4	cz1 ,fz,oz,nz,cz2,cz3,...,czn
GlobalOneToOne	4	cz, fz, ZZ, CZ
GlobalOneToMany	2*nz+4	cz, fz, oz, nz, ZZ1, CZ1, ZZ2, CZ2, ...,ZZn, CZn

Where:

cz = cell in current zone

fz = face of cell in current zone

oz = face obscuration flag (only applies to one-to-many):

0 = face partially obscured

1 = face entirely obscured

nz = number of cell or zone/cell associations (only applies to one-to-many)

ZZ = remote Zone

CZ = cell in remote zone

cz,fz combinations must be unique. Additionally, Tecplot 360 assumes that with the one-to-one face neighbor modes a supplied cell face is entirely obscured by its neighbor. With one-to-many, the obscuration flag must be supplied. Faces that are not supplied with neighbors are run through Tecplot 360's auto face neighbor generator (FE only).

The face numbers for cells in the various zone types are defined in [Figure 3-1](#).

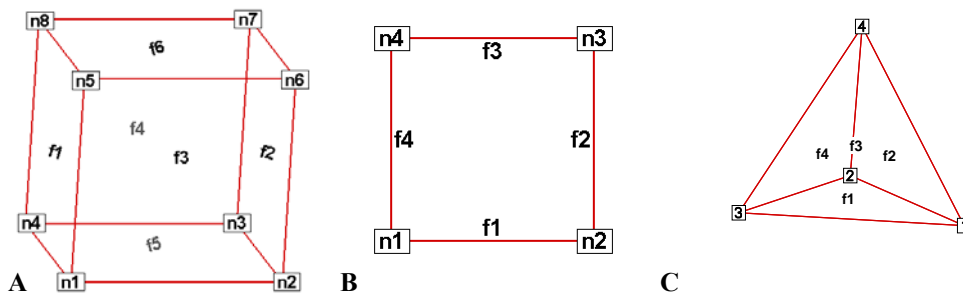

Figure 3-1. A: Example of node and face neighbors for an fe-brick cell or IJK-ordered cell.  
 B: Example of node and face numbering for an IJ-ordered cell.  
 C: example of tetrahedron face neighbors.

### Example

Refer to [Section 3- 9.1 “Face Neighbors”](#) for an example of working with face neighbors. In this example, face neighbors are used to prevent an Edge line from being drawn between the two zones.

---

## TECFIL112

Switch output context to a different file. Each time [TECINI112](#) is called the file context is switched to a different file. This allows you to write multiple data files at the same time. When working with multiple files, be sure to call [TECFIL112](#) each time you wish to write to a file. This will ensure your data is written to the appropriate file.

### ***FORTRAN Syntax:***

```
INTEGER*4 FUNCTION TECFIL112 (F)
INTEGER*4                                F
```

### ***C Syntax:***

```
#include TECIO.h
INTEGER4 TECFIL112 (INTEGER4 *F) ;
```

### ***Return Value:***

0 if successful, -1 if unsuccessful.

***Parameters:***

Parameter	Description
F	Pointer to integer specifying file number to switch to. A value of 1 indicates a switch to the file opened by the first call to <a href="#">TECINI112</a> .

***Examples***

Refer to [Section 3- 9.7 “Switching between two files”](#) for a simple example of working with **TECFIL112**.

---

**TECFOREIGN112**

---

Optional function that sets the byte ordering request for subsequent calls to [TECINI112](#). The byte ordering request will remain in effect until the next call to this function. This has no effect on files already opened via [TECINI112](#). Use this function to reverse the byte ordering from the format native to your operating system. For example, this is useful if you are creating a file on an SGI machine to be used on a Windows or Intel-based Linux machine. If the function call is omitted, native byte ordering will be used.

***FORTRAN Syntax:***

```
INTEGER*4 FUNCTION TECFOREIGN112 (DoForeignByteOrder)
INTEGER*4 DoForeignByteOrder
```

***C Syntax:***

```
#include TECIO.h
INTEGER4 TECFOREIGN112 (INTEGER4 *DoForeignByteOrder) ;
```

***Return Value:***

0 if successful, -1 if unsuccessful.

**Parameters:**

Parameter	Description
<b>DoForeignByteOrder</b>	Pointer to boolean value indicating if future files created by <a href="#">TECINI112</a> should be written out in foreign byte order. 0 indicates native byte order. 1 indicates foreign byte order.

**TECGEO112**

Adds a geometry object to the file (e.g. a circle or a square). NOTE: you cannot set unused parameters to NULL. You must use dummy values for unused parameters.

**FORTRAN Syntax:**

```

INTEGER*4 FUNCTION TECGEO112 ( XOrThetaPos,
&                               YOrRPos,
&                               ZPos,
&                               PosCoordMode,
&                               AttachToZone,
&                               Zone,
&                               Color,
&                               FillColor,
&                               IsFilled,
&                               GeomType,
&                               LinePattern,
&                               PatternLength,
&                               LineThicknessness,
&                               NumEllipsePts,
&                               ArrowheadStyle,
&                               ArrowheadAttachment,
&                               ArrowheadSize,
&                               ArrowheadAngle,
&                               Scope,
&                               Clipping,
&                               NumSegments,
&                               NumSegPts,
&                               XOrThetaGeomData,
&                               YOrRGeomData,
&                               ZGeomData,
&                               MFC)
DOUBLE PRECISION XOrThetaPos
DOUBLE PRECISION YOrRPos
DOUBLE PRECISION ZPos
INTEGER*4 PosCoordMode
INTEGER*4 AttachToZone
INTEGER*4 Zone
INTEGER*4 Color
INTEGER*4 FillColor

```

INTEGER*4	IsFilled
INTEGER*4	GeomType
INTEGER*4	LinePattern
DOUBLE PRECISION	PatternLength
DOUBLE PRECISION	LineThicknessness
INTEGER*4	NumEllipsePts
INTEGER*4	ArrowheadStyle
INTEGER*4	ArrowheadAttachment
DOUBLE PRECISION	ArrowheadSize
DOUBLE PRECISION	ArrowheadAngle
INTEGER*4	Scope
INTEGER*4	Clipping
INTEGER*4	NumSegments
INTEGER*4	NumSegPts
REAL*4	XOrThetaGeomData
REAL*4	YOrRGeomData
REAL*4	ZGeomData
CHARACTER* (*)	MFC

### *C Syntax:*

```
#include TECIO.h
INTEGER4  TECGEO112 (double *XOrThetaPos,
double    *YOrRPos,
double    *ZPos,
INTEGER4  *PosCoordMode,
INTEGER4  *AttachToZone,
INTEGER4  *Zone,
INTEGER4  *Color,
INTEGER4  *FillColor,
INTEGER4  *IsFilled,
INTEGER4  *GeomType,
INTEGER4  *LinePattern,
double    *PatternLength,
double    *LineThicknessness,
INTEGER4  *NumEllipsePts,
INTEGER4  *ArrowheadStyle,
INTEGER4  *ArrowheadAttachment,
double    *ArrowheadSize,
double    *ArrowheadAngle,
INTEGER4  *Scope,
INTEGER4  *Clipping,
INTEGER4  *NumSegments,
INTEGER4  *NumSegPts,
float     *XOrThetaGeomData,
float     *YOrRGeomData,
float     *ZGeomData,
char      *MFC
```

### *Return Value:*

0 if successful, -1 if unsuccessful.

**Parameters:**

Parameter	Description
XPos	Pointer to double value specifying the X- position or, for polar line plots, the Theta-position of the geometry.
or	
ThetaPos	
YPos	Pointer to double value specifying the Y-position or, for polar line plots, the R-position of the geometry.
or	
RPos	
ZPos	Pointer to double value specifying the Z-position of the geometry.
PosCoordMode	Pointer to integer value specifying the position coordinate system. <b>0=Grid</b> <b>1=Frame</b> <b>6=Grid3D</b> Grid3D is available only when the <a href="#">GeomType</a> is equal to 3D Line Segments.
AttachToZone	Pointer to integer flag to signal that the geometry is “attached” to a zone. When a geometry is attached to a zone, it will be visible only when that zone is visible. <b>1 = Yes</b> <b>0 = No</b>
Zone	Pointer to integer value specifying the number of the zone to attach to. Must be greater than or equal to one.
Color	Pointer to integer value specifying the color to assign to the geometry. <b>0=Black</b> <b>8=Custom1</b> <b>1=Red</b> <b>9=Custom2</b> <b>2=Green</b> <b>10=Custom3</b> <b>3=Blue</b> <b>11=Custom4</b> <b>4=Cyan</b> <b>12=Custom5</b> <b>5=Yellow</b> <b>13=Custom6</b> <b>6=Purple</b> <b>14=Custom7</b> <b>7=White</b> <b>15=Custom8</b>
FillColor	Pointer to integer value specifying the color used to fill the geometry. Refer to <a href="#">Color</a> for a list of available values.
IsFilled	Pointer to integer flag to specify if geometry is to be filled. <b>1 = Yes</b> <b>0 = No</b>

Parameter	Description
GeomType	Pointer to integer value specifying the geometry type. <b>0=2D Line Segments</b> <b>3=Circle</b> <b>1=Rectangle</b> <b>4=Ellipse</b> <b>2=Square</b> <b>5=3D Line Segments</b>
LinePattern	Pointer to integer value specifying the line pattern. <b>0=Solid</b> <b>3=Dotted</b> <b>1=Dashed</b> <b>4=LongDash</b> <b>2=DashDot</b> <b>5=DashDotDot</b>
PatternLength	Pointer to double value specifying the pattern length in frame units (from 0.01 and less than 100).
LineThicknessness	Pointer to double value specifying the line thickness in frame units. The value must be greater than 0.0001 and less than 100.
NumEllipsePts	Pointer to integer value specifying the number of points to use for circles and ellipses. The value must be between 2 and 720.
ArrowheadStyle	Pointer to integer value specifying the arrowhead style. <b>0=Plain</b> <b>2=Hollow</b> <b>1=Filled</b>
ArrowheadAttachment	Pointer to integer value specifying where to attach arrowheads. <b>0=None</b> <b>2=End</b> <b>1=Beginning</b> <b>3=Both</b>
ArrowheadSize	Pointer to double value specifying the arrowhead size in frame units (from 0 to 100).
ArrowheadAngle	Pointer to double value specifying the arrowhead angle in degrees.
Scope	Pointer to integer value specifying the scope with respect to frames. A local scope places the object in the active frame. A global scope places the object in all frames that contain the active frame's data set. <b>0=Global</b> <b>1=Local.</b>
Clipping	Specifies whether to clip the geometry (that is, only plot the geometry within) to the viewport or the frame. <b>0=ClipToViewport</b> <b>1=ClipToFrame.</b>
NumSegments	Pointer to integer value specifying the number of polyline segments.
NumSegPts	Array of integer values specifying the number of points in each of the <a href="#">Num-Segments</a> segments.

Parameter	Description
XGeomData	Array of floating-point values specifying the X-, Y- and Z-coordinates. Refer to <a href="#">“Data Values”</a> on page 41 for information regarding the values required for each <a href="#">GeomType</a> .
ThetaGeomData	
YGeomData	
RGeomData	
ZGeomData	
MFC	Macro function command. Must be null terminated.

### Examples

Refer to [Section 3-9.9 “Geometry Example”](#) for a simple example of working with **TECGEO112**.

### Origin positions

The origin (**XOrThetaPos**, **YOrRPos**, **ZPos**) of each geometry type is listed below:

- **SQUARE** - lower left corner at **XOrThetaPos**, **YOrRPos**.
- **RECTANGLE** - lower left corner at **XOrThetaPos**, **YOrRPos**.
- **CIRCLE** - centered at **XOrThetaPos**, **YOrRPos**.
- **ELLIPSE** - centered at **XOrThetaPos**, **YOrRPos**.
- **LINE** - anchored at **XOrThetaPos**, **YOrRPos**.
- **LINE3D** - anchored at **XOrThetaPos**, **YOrRPos**, **ZPos**.

### Data Values

The origin (**XOrThetaGeomData**, **YOrRGeomData**, **ZGeomData**) of each geometry type is listed below:

- **SQUARE** - set **XOrThetaGeomData** equal to the desired length.
- **RECTANGLE** - set **XOrThetaGeomData** equal to the desired width and **YOrThetaGeomData** equal to the desired height.
- **CIRCLE** - set **XOrThetaGeomData** equal to the desired radius.
- **ELLIPSE** - set **XOrThetaGeomData** equal to the desired width along the x-axis and **YOrThetaGeomData** equal to the desired width along the y-axis.
- **LINE** - specify the coordinate positions for the data points in each line segment with **XOrThetaGeomData** and **YOrRGeomData**.

- **LINE3D** - specify the coordinate positions for the data points in each line segment with **XOrThetaGeomData**, **YOrRGeomData** and **ZGeomData**.

---

**TECINI12**

---

Initializes the process of writing a binary data file. This must be called *first* before any other **TECIO** calls are made (except [TECFORIGN12](#)). You may write to multiple files by calling **TECINI12** more than once. Each time **TECINI12** is called, a new file is opened. Use [TECFIL12](#) to switch between files. For each call to **TECINI**, there must be a corresponding call to [TECEND12](#).

***FORTRAN Syntax:***

```
INTEGER*4 FUNCTION TECINI12( Title,
&                               Variables,
&                               FName,
&                               ScratchDir,
&                               FileType,
&                               Debug,
&                               VIsDouble)
CHARACTER*(*) Title
CHARACTER*(*) Variables
CHARACTER*(*) ScratchDir
CHARACTER*(*) FName
INTEGER*4    FileType
INTEGER*4    Debug
INTEGER*4    VIsDouble
```

***C Syntax:***

```
#include TECIO.h
INTEGER4 TECINI12(char *Title,
                  char *Variables,
                  char *FName,
                  char *ScratchDir,
                  INTEGER4 *FileType,
                  INTEGER4 *Debug,
                  INTEGER4 *VIsDouble);
```

***Return Value:***

0 if successful, -1 if unsuccessful.

**Parameters:**

Parameter	Description
Title	Title of the data set. <i>Must be null terminated.</i>
Variables	List of variable names. If a comma appears in the string it will be used as the separator between variable names, otherwise a space is used. <i>Must be null terminated.</i>
FName	Name of the file to create. <i>Must be null terminated.</i>
ScratchDir	Name of the directory to put the scratch file. <i>Must be null terminated.</i>
FileType	Specify whether the file is a full data file (containing both grid and solution data), a grid file or a solution file. <p style="text-align: center;">0=Full 1=Grid            2=Solution</p>
Debug	Pointer to the integer flag for debugging. Set to 0 for no debugging or 1 to debug. When set to 1, the debug messages will be sent to the standard output (stdout).
VisDouble	Pointer to the integer flag for specifying whether field data generated in future calls to <a href="#">TECDAT112</a> are to be written in single or double precision. <p style="text-align: center;">0=Single        1=Double.</p>

**Examples**

Each example in [Section 3 - 9 “Examples”](#) calls `TECINI112` at least once. Refer to this section for details.

**TECLAB112**

Adds custom labels to the data file. Custom Labels can be used for axis labels, legend text, and tick mark labels. The first custom label string corresponds to a value of one on the axis, the next to a value of two, the next to a value of three, and so forth. NOTE: To work with custom labels, you must have at least one zone in your data set. A custom label set is added to your file each time you call `TECLAB112`. You may have up to sixty labels in a set and up to ten sets in a file. Each label must be surrounded by double-quotes, e.g. “Mon” “Tues” “Wed”, etc.

Custom labels are assigned to an object via the Tecplot interface. Refer to [Section 17- 7.1 “Creating Custom Labels”](#) in the [User’s Manual](#) for details.

**FORTRAN Syntax:**

```
INTEGER*4 FUNCTION TECLAB112 (Labels)
CHARACTER* (*)                    Labels
```

***C Syntax:***

```
#include TECIO.h
INTEGER4 TECLAB112(char *Labels);
```

***Return Value:***

0 if successful, -1 if unsuccessful.

***Parameters:***

Parameter	Description
Labels	Character string of custom labels. Each label must be surrounded by double-quotes. Separate labels by a comma or space. You may have up to sixty labels in each call to <code>TECLAB112</code> .

***Examples***

To add the days of the week to your data file, to be displayed along the x-axis:

```
char    Labels[60] = "\"Mon\", \"Tues\", \"Wed\", \"Thurs\", \"Fri\"";
TECLAB112(&Labels[0]);
```

---

**TECNOD112**

---

Writes an array of node data to the binary data file. This is the connectivity list for cell-based finite element zones (line segment, triangle, quadrilateral, brick, and tetrahedral zones). The connectivity list for face-based finite element zones (polygonal and polyhedral) is specified via [TECPOLY112](#).

***FORTRAN Syntax:***

```
INTEGER*4 FUNCTION TECNOD112(NData)
INTEGER*4 NData (T, M)
```

***C Syntax:***

```
#include TECIO.h
INTEGER4 TECNOD112(INTEGER4 *NData);
```

***Return Value:***

0 if successful, -1 if unsuccessful.

---

**Parameters:**

Parameter	Description						
NData	<p>Array of integers listing the nodes for each element. This is the connectivity list, dimensioned (T, M) (T moving fastest), where M is the number of elements in the zone and T is set according to the following list:</p> <table style="margin-left: auto; margin-right: auto;"> <tr> <td>2=Line Segment</td> <td>4=Tetrahedral</td> </tr> <tr> <td>3=Triangle</td> <td>8=Brick</td> </tr> <tr> <td>4=Quadrilateral</td> <td></td> </tr> </table>	2=Line Segment	4=Tetrahedral	3=Triangle	8=Brick	4=Quadrilateral	
2=Line Segment	4=Tetrahedral						
3=Triangle	8=Brick						
4=Quadrilateral							

**Examples:**

Refer to [Section 3-9.1 “Face Neighbors”](#) for examples using TECNOD112.

**TECPOLY112**

Writes the face map for polygonal and polyhedral zones to the data file. All numbering schemes are one-based. The first node is Node 1, the first face is Face 1, and so forth. Refer to [Section 3 - 8 “Defining Polyhedral and Polygonal Data”](#) on page 58 for additional information.

Avoid creating concave objects (or bad meshes), as they will not look good when plotted.

**FORTRAN syntax:**

```

INTEGER*4 FUNCTION TECPOLY112 (
&
&                               FaceNodeCounts,
&                               FaceNodes,
&                               FaceLeftElems,
&                               FaceRightElems,
&                               FaceBndryConnectionCounts,
&                               FaceBndryConnectionElems,
&                               FaceBndryConnectionZones)
&
&   INTEGER*4
&   INTEGER*4                               FaceNodeCounts (*)
&   INTEGER*4                               FaceNodes (*)
&   INTEGER*4                               FaceLeftElems (*)
&   INTEGER*4                               FaceRightElems (*)
&   INTEGER*4                               FaceBndryConnectionCounts (*)
&   INTEGER*4                               FaceBndryConnectionElems (*)
&   INTEGER*2                               FaceBndryConnectionZones (*)

```

**C Syntax:**

```

include TECIO.h
INTEGER4 TECPOLY112 (INTEGER4           *FaceNodeCounts,
                    INTEGER4           *FaceNodes,
                    INTEGER4           *FaceLeftElems,
                    INTEGER4           *FaceRightElems,

```

```

INTEGER4      *FaceBndryConnectionCounts,
INTEGER4      *FaceBndryConnectionElems,
INTEGER4      *FaceBndryConnectionZones);

```

***Return Value:***

0 if successful, -1 if unsuccessful.

***Parameters:***

Parameter	Description
FaceNodeCounts	An array used to define the number of nodes in each face. The array is dimensioned by the number of faces (defined in <a href="#">TECZNE112</a> ). This is NULL for polygonal zones, as each face in a polygonal zone has exactly two nodes.
FaceNodes	An array used to specify which nodes belong to which face. The array is dimensioned by TotalNumFaceNodes (defined in <a href="#">TECZNE112</a> ).
FaceLeftElems	An array used to define the left neighboring element for each face. The array is dimensioned by NumFaces (defined in <a href="#">TECZNE112</a> ).
FaceRightElems	An array used to define the right neighboring element for each face. The array is dimensioned by NumFaces (defined in <a href="#">TECZNE112</a> ).
FaceBndryConnectionCounts	An array used to define the number of boundary connections for each boundary face. The array is dimensioned by NumConnectedBoundaryFaces (defined in <a href="#">TECZNE112</a> ).
FaceBndryConnectionElems	An array used to define the boundary element(s) to which each boundary face is connected. The array is dimensioned by TotalNumBndryConnections (defined in <a href="#">TECZNE112</a> ).
FaceBndryConnectionZones	An array used to define the zone(s) to which each boundary element belongs. The array is dimensioned by TotalNumBndryConnections (defined in <a href="#">TECZNE112</a> ).

***Examples***

Refer to the following sections for examples using **TECPOLY112**:

- [Section 3- 9.2 “Polygonal Example”](#)
- [Section 3- 9.3 “Multiple Polyhedral Zones”](#)
- [Section 3- 9.4 “Multiple Polygonal Zones”](#)

- [Section 3- 9.5 “Polyhedral Example”](#)

---



---

**TECTXT112**

---

Adds a text box to the file.

***FORTRAN Syntax:***

```

    INTEGER*4 FUNCTION TECTXT112(  XOrThetaPos,
&                                YOrRPos,
&                                ZOrUnusedPos,
&                                PosCoordMode,&
&                                AttachToZone,
&                                Zone,
&                                Font,
&                                FontHeightUnits,
&                                FontHeight,
&                                BoxType,
&                                BoxMargin,
&                                BoxLineThicknessness,
&                                BoxColor,
&                                BoxFillColor,
&                                Angle,
&                                Anchor,
&                                LineSpacing,
&                                TextColor,
&                                Scope,
&                                Clipping,
&                                Text,
&                                MFC)
    DOUBLE PRECISION  XOrThetaPos
    DOUBLE PRECISION  YOrRPos
    DOUBLE PRECISION  ZOrUnusedPos
    INTEGER*4         PosCoordMode
    INTEGER*4         AttachToZone
    INTEGER*4         Zone
    INTEGER*4         Font
    INTEGER*4         FontHeightUnits
    DOUBLE PRECISION  FontHeight
    INTEGER*4         BoxType
    DOUBLE PRECISION  BoxMargin
    DOUBLE PRECISION  BoxLineThicknessness
    INTEGER*4         BoxColor
    INTEGER*4         BoxFillColor
    DOUBLE PRECISION  Angle
    INTEGER*4         Anchor
    DOUBLE PRECISION  LineSpacing
    INTEGER*4         TextColor
    INTEGER*4         Scope
    INTEGER*4         Clipping
    CHARACTER* (*)    Text
    CHARACTER* (*)    MFC

```

***C Syntax:***

```
#include TECIO.h
INTEGER4 TECTXT112 (double      *XOrThetaPos,
                           double *YOrRPosPos,
                           double *ZOrUnusedPos,
                           INTEGER4 *PosCoordMode,
                           INTEGER4 *AttachToZone,
                           INTEGER4 *Zone,
                           INTEGER4 *Font,
                           INTEGER4 *FontHeightUnits,
                           double *FontHeight,
                           INTEGER4 *BoxType,
                           double *BoxMargin,
                           double *BoxLineThicknessness,
                           INTEGER4 *BoxColor,
                           INTEGER4 *BoxFillColor,
                           double *Angle,
                           INTEGER4 *Anchor,
                           double *LineSpacing,
                           INTEGER4 *TextColor,
                           INTEGER4 *Scope,
                           INTEGER4 *Clipping,
                           char *Text,
                           char *MFC)
```

***Return Value:***

0 if successful, -1 if unsuccessful.

**Parameters:**

<b>Parameter</b>	<b>Description</b>
XOrThetaPos	Pointer to double value specifying the X-position or Theta-position (polar plots only) of the text.
YOrRPos	Pointer to double value specifying the Y-position or R-position (polar plots only) of the text.
ZOrUnusedPos	Pointer to double value specifying the Z-position of the text.
PosCoordMode	Pointer to integer value specifying the position coordinate system. <b>0=Grid</b> <b>1=Frame</b> <b>6=Grid3D</b> If you use Grid3D, the plot type must be set to 3D Cartesian to view your text box.
AttachToZone	Pointer to integer flag to signal that the text is “attached” to a zone.
Zone	Pointer to integer value specifying the zone number to attach to.
Font	Pointer to integer value specifying the font. <b>0=Helvetica</b> <b>6=Times Italic</b> <b>1=Helvetica Bold</b> <b>7=Times Bold</b> <b>2=Greek</b> <b>8=Times Italic Bold</b> <b>3=Math</b> <b>9=Courier</b> <b>4=User-Defined</b> <b>10=Courier Bold</b> <b>5=Times</b>
FontHeightUnits	Pointer to integer value specifying the font height units. <b>0=Grid</b> <b>2=Point</b> <b>1=Frame</b>
FontHeight	Pointer to double value specifying the font height. If <a href="#">PosCoordMode</a> is set to FRAME, the value range is zero to 100.
BoxType	Pointer to integer value specifying the box type. <b>0=None</b> <b>2=Hollow</b> <b>1=Filled</b>
BoxMargin	Pointer to double value specifying the box margin (in frame units ranging from 0 to 100).
BoxLineThickness	Pointer to double value specifying the box line thickness (in frame units ranging from 0 to 100).



***FORTRAN Syntax:***

```
INTEGER*4 FUNCTION TECUSR112 (S)
CHARACTER*(*) S
```

***C Syntax:***

```
#include TECIO.h
INTEGER4 TECUSR112 (CHAR *S);
```

***Return Value:***

0 if successful, -1 if unsuccessful.

***Parameters:***

Parameter	Description
S	The character string to write to the data file. Must be null-terminated.

---

**TECVAUXSTR112**

---

Writes an auxiliary data item to the data file for the specified variable. Must be called after [TECINI112](#) and before [TECEND112](#). Auxiliary data may be used by text, macros, equations (if it is numeric) and add-ons. It may be viewed directly in the *Aux Data* page of the **Data Set Information** dialog (accessed via the **Data** menu). The value can be verified by selecting “Variable” from the “Show Auxiliary Data” menu and selecting the corresponding variable number from the menu.

***FORTRAN Syntax:***

```
INTEGER*4 FUNCTION TECVAUXSTR112 (Var, Name, Value)
INTEGER*4      Var
CHARACTER*(*)  Name
CHARACTER*(*)  Value
```

***C Syntax:***

```
#include TECIO.h
INTEGER4 TECVAUXSTR112 (INTEGER4 *Var,
                        char *Name,
                        char *Value);
```

***Return Value:***

0 if successful, -1 if unsuccessful.

**Parameters:**

Parameter	Description
<b>Var</b>	The variable number for which to set the auxiliary data. Variable numbers start at one.
<b>Name</b>	The name of the auxiliary data item. If a data item with this name already exists, its value will be overwritten. Must be a null-terminated character string and cannot contain spaces.
<b>Value</b>	The auxiliary data value to be written to the data file. Must be a null-terminated character string.

**Example:**

The following example illustrates adding auxiliary data to the pressure variable in the data file. In this case, pressure is the third variable.

```

INTEGER4 Var                = 3;
char      PressureUnitsName[16] = "PressureUnits";
char      PressureUnitsValue[16] = "Pascal (Pa)";

TECVAUXSTR112 (&Var,
               &PressureUnitsName[0],
               &PressureUnitsValue[0]);

```

**TECZAUXSTR112**

Writes an auxiliary data item for the current zone to the data file. Must be called immediately after [TECZNE112](#) for the desired zone. Auxiliary data may be used by text, macros, equations (if it is numeric) and add-ons. It may be viewed directly in the *Aux Data* page of the **Data Set Information** dialog (accessed via the **Data** menu). The value can be verified by selecting “Zone” from the “Show Auxiliary Data” menu and selecting the corresponding zone number.

**FORTRAN Syntax:**

```

INTEGER*4 FUNCTION TECZAUXSTR112 (Name, Value)
CHARACTER* (*)      Name
CHARACTER* (*)      Value

```

**C Syntax:**

```

#include TECIO.h
INTEGER4 TECZAUXSTR112 (char *Name,
                       char *Value);

```

**Return Value:**

0 if successful, -1 if unsuccessful.

**Parameters:**

Parameter	Description
<b>Name</b>	The name of the auxiliary data item. If a data item with this name already exists, its value will be overwritten. Must be a null-terminated character string and cannot contain spaces.
<b>Value</b>	The auxiliary data value to be written to the data file. Must be a null-terminated character string.

**Example:**

The following example code adds auxiliary data to the zone. NOTE: **TECZAUXSTR112** must be called immediately after [TECZNE112](#) for the desired zone.

```
char    CreatedByName[16]    = "CreatedBy";
char    CreatedByValue[16]  = "My Company";

TECZAUXSTR112 (&CreatedByName[0],
              &CreatedByValue[0]);
```

**TECZNE112**

Writes header information about the next zone to be added to the data file. After **TECZNE112** is called, you must call [TECDAT112](#) one or more times. If the zone is a finite element zone, call [TECNOD112](#)(cell-based zones) or [TECPOLY112](#) (face-based zones) after calling [TECDAT112](#).



When specifying your [ZoneType](#), please note that some features in Tecplot 360 are limited by zone type. For example, iso-surfaces and slices are available for 3D zones types only (FETETRAHEDRON, FEBRICK, FEPOLYHEDRON and ORDERED - with K greater than 1).

However, the plot type that you specify (in Tecplot 360 once you have loaded your data) is not limited by your zone type. You may have a 3D zone displayed in a 2D Cartesian plot (and visa versa).

*FORTRAN Syntax:*

```

INTEGER*4 FUNCTION TECZNE112 (ZoneTitle,
&                               ZoneType,
&                               IMxOrNumPts,
&                               JMxOrNumElements,
&                               KMxOrNumFaces,
&                               ICellMax,
&                               JCellMax,
&                               KCellMax,
&                               SolutionTime,
&                               StrandID,
&                               ParentZone,
&                               IsBlock,
&                               NumFaceConnections,
&                               FaceNeighborMode,
&                               TotalNumFaceNodes,
&                               NumConnectedBoundaryFaces,
&                               TotalNumBoundaryConnections,
&                               PassiveVarList,
&                               ValueLocation,
&                               ShareVarFromZone,
&                               ShareConnectivityFromZone)
CHARACTER* (*) ZoneTitle
INTEGER*4 ZoneType
INTEGER*4 IMxOrNumPts
INTEGER*4 JMxOrNumElements
INTEGER*4 KMxOrNumFaces
INTEGER*4 ICellMax
INTEGER*4 JCellMax
INTEGER*4 KCellMax
DOUBLE PRECISION SolutionTime
INTEGER*4 StrandID
INTEGER*4 ParentZone
INTEGER*4 IsBlock
INTEGER*4 NumFaceConnections
INTEGER*4 FaceNeighborMode
INTEGER*4 TotalNumFaceNodes,
INTEGER*4 NumConnectedBoundaryFaces,
INTEGER*4 TotalNumBoundaryConnections,
INTEGER*4 PassiveVarList
INTEGER*4 ValueLocation
INTEGER*4 ShareVarFromZone (*)
INTEGER*4 ShareConnectivityFromZone

```

*C Syntax:*

```

#include TECIO.h

INTEGER4      TECZNE112 (char
                    INTEGER4      *ZoneTitle,
                    INTEGER4      *ZoneType,
                    INTEGER4      *IMxOrNumPts,
                    INTEGER4      *JMxOrNumElements,
                    INTEGER4      *KMxOrNumFaces,
                    INTEGER4      *ICellMax,

```

```

INTEGER4      *JCellMax,
INTEGER4      *KCellMax,
DOUBLE        *SolutionTime,
INTEGER4      *StrandID,
INTEGER4      *ParentZone,
INTEGER4      *IsBlock,
INTEGER4      *NumFaceConnections,
INTEGER4      *FaceNeighborMode,
INTEGER4      *TotalNumFaceNodes,
INTEGER4      *NumConnectedBoundaryFaces,
INTEGER4      *TotalNumBoundaryConnections,
INTEGER4      *PassiveVarList,
INTEGER4      *ValueLocation,
INTEGER4      *ShareVarFromZone,
INTEGER4      *ShareConnectivityFromZone)

```

**Return Value:**

0 if successful, -1 if unsuccessful.

**Parameters:**

Parameter	Applies to Zone Type(s)	Notes
ZoneTitle	ALL	The title of the zone. Must be null-terminated.
ZoneType	ALL	The type of the zone: 0=ORDERED 1=FELINESEG 2=FETRIANGLE 3=FEQUADRILATERAL 4=FETETRAHEDRON 5=FEBRICK 6=FEPOLYGON 7=FEPOLYHEDRON
IMax or NumPts	ALL	For ordered zones, the number of nodes in the I-index direction. For finite element zones (cell-based and face-based), the number of nodes.
JMax or NumElements	ALL	For ordered zones, the number of nodes in the J index direction. For finite element zones (cell-based and face-based), the number of elements.
KMax or NumFaces	ORDEREDFEPOLY- GON FEPOLYHEDRON	For ordered zones, the number of nodes in the K index direction. For polyhedral and polygonal finite element zones, it is the number of faces. Not used all other finite element zone types.
ICellMax	N/A	Reserved for future use. Set to zero.

Parameter	Applies to Zone Type(s)	Notes
JCellMax	N/A	Reserved for future use. Set to zero.
KCellMax	N/A	Reserved for future use. Set to zero.
SolutionTime	ALL	Scalar double precision value specifying the time associated with the zone. Refer to <a href="#">Section 7 - 2 “Time Aware”</a> in the <a href="#">User’s Manual</a> for additional information on working with transient data.
StrandID	ALL	<p>Scalar integer value specifying the strand to which the zone is associated.</p> <p>0 = static zone, not associated with a strand. Values greater than 0 indicate a zone is assigned to a given strand.</p> <p>Refer to <a href="#">Section 7 - 2 “Time Aware”</a> in the <a href="#">User’s Manual</a> for additional information on strands.</p> <p>If you are converting your function calls from function calls 109 or older, use “0” for StrandID.</p>
ParentZone	ALL	<p>Scalar integer value representing the relationship between this zone and its parent. With a parent zone association, Tecplot 360 can generate a surface streamtrace on a no-slip boundary zone. A zone may not specify itself as its own parent.</p> <p>0 = indicates that this zone is not associated with a parent zone. &gt;0 = A value greater than zero is considered this zone's parent.</p> <p>Refer to <a href="#">Section 7 - 2 “Time Aware”</a> in the <a href="#">User’s Manual</a> for additional information on parent zones and <a href="#">Section 15 - 3 “Surface Streamtraces on No-slip Boundaries”</a> in the <a href="#">User’s Manual</a> for additional information regarding no-slip boundaries.</p>
IsBlock	ALL	Indicates that data will be passed into <a href="#">TECDAT112</a> in BLOCK format. Always use 1 to indicate the BLOCK format, as TecZne functions do not output in point format.

Parameter	Applies to Zone Type(s)	Notes
NumFaceConnections	ORDERED FELINESEG FETRIANGLE FEQUADRILATERAL FETETRAHEDRON FEBRICK	Used for cell-based finite element and ordered zones only. The number of face connections that will be passed in routine <a href="#">TECFACE112</a> .
FaceNeighborMode	ORDERED FELINESEG FETRIANGLE FEQUADRILATERAL FETETRAHEDRON FEBRICK	Used for cell-based <sup>a</sup> finite element and ordered zones only. The type of face connections that will be passed in routine <a href="#">TECFACE112</a> . <b>0=LocalOneToOne</b> <b>2=GlobalOneToOne</b> <b>1=LocalOneToMany</b> <b>3=GlobalOneToMany</b>
TotalNumFaceNodes	FEPOLYGON FEPOLYHEDRON	Used for face-based <sup>b</sup> finite element zones. Total number of nodes for all faces. It is also the sum of the FaceNodeCounts array (defined in <a href="#">TECPOLY112</a> ). For polygonal zones this value is equivalent to 2 * NumFaces. NumFaces = the number of faces in the zone. Refer to <a href="#">Section 3- 8.2 “FaceNodeCounts and FaceNodes”</a> for simple example.
NumConnected-BoundaryFaces	FEPOLYGON FEPOLYHEDRON	Used for face-based <sup>b</sup> finite element zones. Total number of boundary faces, where boundary faces are faces that either have more than one neighboring cell on a side or have a neighboring cell from another zone. Refer to <a href="#">Section 3- 8.1 “Boundary Faces and Boundary Connections”</a> for simple example.
TotalNumBoundary-Connections	FEPOLYGON FEPOLYHEDRON	Used for face-based <sup>b</sup> finite element zones. Total number of boundary connections for all faces. In general, <a href="#">TotalNumBoundaryConnections</a> will be equal to <a href="#">NumConnectedBoundaryFaces</a> . However, <a href="#">TotalNumBoundaryConnections</a> must be greater than or equal to <a href="#">NumConnectedBoundaryFaces</a> . Refer to <a href="#">Section 3- 8.1 “Boundary Faces and Boundary Connections”</a> for simple example.
PassiveVarList	ALL	Array, dimensioned by the number of variables, of 4 byte integer values specifying the active/passive nature of each variable. A value of 0 indicates the associated variable is active while a value of 1 indicates that it is passive. Refer to <a href="#">“Passive Variables”</a> on page 9 for additional information.

Parameter	Applies to Zone Type(s)	Notes
ValueLocation	ALL	The location of each variable in the data set. Value-Location(I) indicates the location of variable I for this zone. 0=cell-centered, 1=node-centered. Pass null to indicate that all variables are node-centered.
ShareVarFromZone	ALL	Indicates variable sharing. Array, dimensioned by the number of variables. ShareVarFromZone(I) indicates the zone number with which variable I will be shared. This reduces the amount of data to be passed via <a href="#">TECDAT112</a> . A value of 0 indicates that the variable is not shared. Pass null to indicate no variable sharing for this zone. You must pass null for the first zone in a data set (there is no data available to share).
ShareConnectivity-FromZone	ALL	Indicates the zone number with which connectivity is shared. Pass 0 to indicate no connectivity sharing. You must pass 0 for the first zone in a data set. NOTE: Connectivity and/or face neighbors cannot be shared when the face neighbor mode is set to Global. Connectivity cannot be shared between cell-based and face-based finite element zones.

- a. Cell-based finite element zones: FELINESEG, FETRIANGLE, FEQUADRILATERAL, FETETRAHEDRON, and FEBRICK.
- b. Face-based finite element zones: FEPOLYGON and FEPOLYHEDRON.

### ***Examples:***

Refer to the following examples for illustrations of working with **TECZNE112**:

- [Section 2 - 4 “Face Neighbors”](#)
- [Section 3 - 5 “Writing to Multiple Binary Data Files”](#)
- [Section 3- 9.2 “Polygonal Example”](#)
- [Section 3- 9.3 “Multiple Polyhedral Zones”](#)
- [Section 3- 9.4 “Multiple Polygonal Zones”](#)
- [Section 3- 9.5 “Polyhedral Example”](#)

## **3 - 8 Defining Polyhedral and Polygonal Data**

Polyhedral data is defined using both **TECPOLY112** and **TECZNE112**. Via **TECZNE112** the number of nodes, faces, elements, boundary faces, and boundary connections are specified. **TECPOLY112** is used to specify the face mapping connections for the zone.

Before defining your polyhedral or polygonal data, you should determine the numbering scheme for the nodes, faces and elements in each zone of your data set. The numbering scheme is communicated to Tecplot implicitly by the order in which you supply the data. For example, the first nodal value supplied is for Node 1, followed by the value for Node 2, continuing to node N (where N is the total number of nodes). Similarly, for faces and elements.

The remainder of this section provides simple examples illustrating how to define each of the parameters of **TECPOLY112**.

### 3- 8.1 Boundary Faces and Boundary Connections

A “Connected Boundary Face” is a face with at least one neighboring element that belongs to another zone. Each “Connected Boundary Face” has one or more “Boundary Connections”. A “Boundary Connection” is defined as the element-zone tuple used to identify the neighboring element when the element is part of another zone.

Consider the following picture:

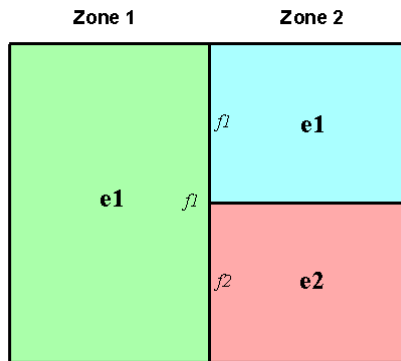

In the figure shown above, Zone 1 contains a single element (e1) and Zone 2 contains two elements (e1 and e2). The boundary faces and boundary connections for each zone are as follows:

- **Zone 1** - In Zone 1, Face 1 (f1) is the sole connected boundary face. It has two boundary connections. The first boundary connection is Element 1 in Zone 2. The second boundary connection is Element 2 in Zone 2.
  - NumConnectedBoundaryFaces = 1
  - TotalNumBndryConnections = 2
- **Zone 2** - In Zone 2, both Face 1 and Face 2 are connected boundary faces. There is a total of two boundary connections. The boundary connection for each boundary face in Zone 2 is Element 1 in Zone 1.
  - NumConnectedBoundaryFaces = 2
  - TotalNumBndryConnections = 2

### 3- 8.2 FaceNodeCounts and FaceNodes

For illustration purposes, consider a zone composed of a single pyramidal element. The pyramid is composed of five nodes and five faces.

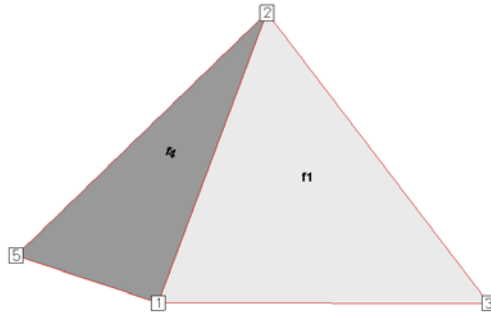

*Figure 3-2.* A simple pyramid. The remaining triangular faces are Faces 2 and 3. The bottom rectangular face is Face 5. Node 4 is obscured from view.

The FaceNodeCounts array is used to specify the number of nodes that compose each face. The values in the array are arranged as follows:

```
FaceNodeCounts = [NumNodesInFace1,
                  NumNodesInFace2,
                  ...
                  NumNodesInFaceF]
```

where  $F$  is the total number of faces in the zone

In this example, the FaceNodeCounts array is: [3 3 3 3 4]. The first four faces are composed of three nodes and the last face is composed of four nodes.

The FaceNodes array is used to specify which nodes belong to which face. The array is dimensioned by the total number of face nodes in the zone (specified via **TECZNE112**). The total number of face nodes is defined as:

$$\sum_{f=1}^F \text{NumNodesInFace}_f$$

The first  $K$  values in the FaceNodes array are the node numbers for Face 1, where  $K$  is the first value in the FaceNodeCounts array. The next  $L$  values are the node numbers for Face 2, where  $L$  is the second value in the FaceNodeCounts array.



When supplying the node numbers for each face, you must supply the numbers in either a clockwise or counter-clockwise configuration around the face. Otherwise, the faces will be contorted when the data is plotted.

It is not important to be consistent when choosing between clockwise or counter-clockwise ordering. The key is to present the numbers consistently within the numbering scheme. For example, you may present the node numbers for face 1 in a clockwise order and the node numbers for the remaining faces in counter-clockwise order.

Consider the pyramid used above. Using the FaceNodeCounts array we have already defined and the figure, we can create the FaceNodes array for the pyramid.

```
FaceNodes = [1, 2, 3
             3, 2, 4,
             5, 2, 4,
             5, 1, 2,
             1, 5, 4, 3]
```

### 3- 8.3 FaceRightElems and FaceLeftElems

After specifying the face map data (using the FaceNodeCounts and FaceNodes array), the next step is to identify the element on either side of each face. To illustrate this, we will switch from the single element zone to the following data set:

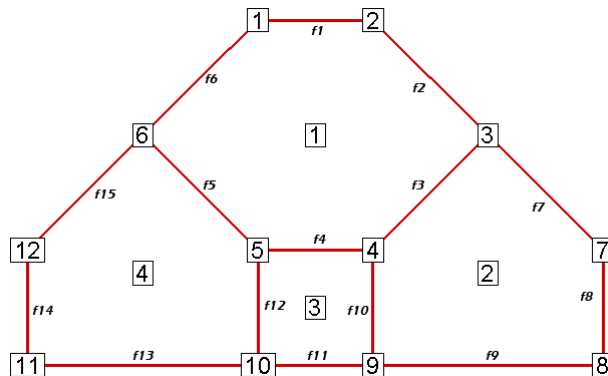

The neighboring elements can be determined using the right-hand rule:

- **2D Data** - For each face, place your right-hand along the face with your fingers pointing in the direction of incrementing node numbers (i.e. from Node 1 to Node 2). The right side of your hand will indicate the right element, and the left side of your hand will indicate the left element.
- **3D Data** - For each face, curl the fingers of your right-hand following the order that the nodes were presented in the FaceNodes array. Your thumb will point to the right element. The left element is the other adjacent element. If the face has more than one neighboring element on a single side, you will need to use the FaceBoundaryConnectionCounts, FaceBoundaryConnectionElems and FaceBoundaryConnectionZones array.

The neighboring elements for each face are stored in the FaceRightElems and FaceLeftElems array. Each array is dimensioned by the total number of faces in the zone. The first value in each array is the right or left neighboring element for Face 1, followed by the neighboring element for Face 2, and so forth.

```

FaceRightElems =   [RightNeighborToFace1,
                   RightNeighborToFace2,
                   ...
                   RightNeighborToFaceF]
FaceLeftElems  =   [LeftNeighborToFace1,
                   LeftNeighborToFace2,
                   ...
                   LeftNeighborToFaceF]

```

where F is the total number of faces

In the above plot, the face neighbors are as follows:

Face Number	Right Neighboring Element	Left Neighboring Element
Face 1	1	0
Face 2	1	0
Face 3	1	2
Face 4	1	3
Face 5	1	4
Face 6	1	0
Face 7	2	0
Face 8	2	0

Face Number	Right Neighboring Element	Left Neighboring Element
Face 9	2	0
Face 10	2	3
Face 11	3	0
Face 12	3	4
Face 13	4	0
Face 14	4	0
Face 15	4	0

The number zero is used to indicate that the face is on the edge of the data (i.e. has “no neighboring element”).

### 3- 8.4 FaceBoundaryConnectionElements and Zones

When working with multiple zones, an additional aspect is folded into the FaceLeftElems and FaceRightElems arrays. When the neighboring element is not within the current zone, you cannot identify the element by its element number alone. Instead you need to specify both the element number and its zone number. This is accomplished using the FaceBoundaryConnectionElements and FaceBoundaryConnectionZones arrays. For each boundary connection, the element number of the boundary connection is stored in the FaceBoundaryConnectionElements array while its zone number is stored in the FaceBoundaryConnectionZones array.

A negative value in the FaceLeftElems or FaceRightElems array is used to indicate that the neighboring element belongs to another zone. The magnitude of the negative number is a pointer to a value in the FaceBoundaryConnectionElements and FaceBoundaryConnectionZones arrays. For example, given the following FaceBoundaryConnectionElements and FaceBoundaryConnectionZones arrays:

```
FaceBoundaryConnectionElements    = [ 1 1 3 4 ]
FaceBoundaryConnectionZones       = [ 2 2 3 3 ]
```

A value of -4 in the FaceLeftElems indicates that the left neighboring element for that face is element four in zone three.

### 3- 8.5 Partially Obscured Boundary Faces

A face on the boundary of a zone may be partially obscured by its boundary connections (neighboring elements). While Tecplot 360 does not draw fully obscured boundary faces (because it treats those faces as internal faces), Tecplot 360 does draw partially obscured boundary faces. Thus, Tecplot 360 requires definition of partially obscured boundary faces.

To indicate a partially obscured face, indicate the appropriate neighboring element as zero in the `FaceBndryConnectionElems` and `FaceBndryConnectionZones` arrays, followed by the actual neighboring elements. When Tecplot 360 sees a list of neighboring elements for a boundary face that begin with element zero, it marks that boundary face as partially obscured.

If Tecplot 360 sees a zero in `FaceBndryConnectionElems` that is not the first boundary element listed for a face, an error message will appear, indicating that either the partially obscured boundary face was not indicated correctly, or `FaceBndryConnectionsElems` and/or `FaceBndryConnectionZones` was not completely filled out.

## 3 - 9 Examples

The following examples (written in C) provide a basic illustration of creating a \*.plt file using the TecIO library. If you plan to compile the examples, be sure to review the instructions in [Section 3 - 6 “Linking with the TecIO Library”](#) first.

In order to keep the examples as simple as possible, error checking is not included. For complete details on the parameters used and the function syntax for each TecIO function, refer to [Section 3 - 7 “Binary Data File Function Reference”](#). When creating a binary data file using the TecIO library, the functions must be called in a specific order. Refer to [Section 3 - 4 “Binary Data File Function Calling Sequence”](#) for details.

### 3- 9.1 Face Neighbors

This example illustrates how to (1) create two simple FE-quadrilateral zones and (2) create a face neighbor connection between the two zones. In order to keep the example as simple as possible, error checking is not included. If you plan to compile this example, be sure to include `TECIO.h`.

For complete details on the parameters used and the function syntax for each TecIO function, refer to [Section 3 - 7 “Binary Data File Function Reference”](#). When creating a binary data file using the TecIO library, the functions must be called in a specific order. Refer to [Section 3 - 4 “Binary Data File Function Calling Sequence”](#) for details.

#### Step 1 Initialize the data file using TECINI

TECINI is required for all data files. It is used to: open the data file and initialize the file header information (name the data file, the variables for the data file, and the file type).

```
INTEGER4 Debug      = 1;
INTEGER4 VIsDouble = 0;
INTEGER4 FileType  = 0;
INTEGER4 NumVars   = 3;
INTEGER4 I         = 0; /* Used to track return codes */
```

```
I = TECINI112("Face Neighbors Example", /* Specifies the name
                                         * of the entire
                                         * dataset
                                         */
             "X Y P", /* Defines the
                       * variables for the
                       * data file. Each
                       * zone must contain
                       * each of the vars
                       * listed. The order
                       * of the variables in
                       * the list is used to
                       * define the variable
                       * number (e.g. X is
                       * Var 1.)
                       */
             "FaceNeighbors.plt", /* Specifies the
                                   * file name.
                                   */
             ".", /* The FileType is set to
                  * zero, indicating it is
                  * a full file (containing
                  * both grid and solution
                  * data).
                  */
             &FileType,
             &Debug,
             &VIsDouble);
```

## Step 2 Create Zone 1

After TECINI is called, call TECZNE to create one or more zones for your data file.

```
INTEGER4 ZoneType = 3; /* set the zone type to
                        * FEQuadrilateral
                        */

INTEGER4 NumPts = 6;
INTEGER4 NumElems = 2;
INTEGER4 NumFaces = 8;
INTEGER4 ICellMax = 0; /* not used */
INTEGER4 JCellMax = 0; /* not used */
INTEGER4 KCellMax = 0; /* not used */
double SolTime = 360.0;
INTEGER4 StrandID = 0; /* StaticZone */
INTEGER4 ParentZn = 0;
INTEGER4 IsBlock = 1; /* Block */
INTEGER4 NFConns = 1; /* Specify the number of Face
                        * Neighbor Connections in the
                        * Zone. When this value is
                        * greater than zero, TECFACE must
                        * be called prior to creating the
                        * next zone or ending the file.
                        */

/* Specify the Face Neighbor Mode.
 * A value of 2 indicated that the face neighbor mode is global
 * one-to-one. The scope of the face neighbors (local or
 * global) is with respect to the zones. A value of global
 * indicates that the face neighbor(s) is/are shared across zones;
 * a value of local indicates that the face neighbor(s) are
 * shared within the current zone. The terms one-to-one and
 * one-to-many are used to indicate whether the face in question
```

```

* is shared with one cell or several cells.
* For example, if your data is arranged as follows:

```

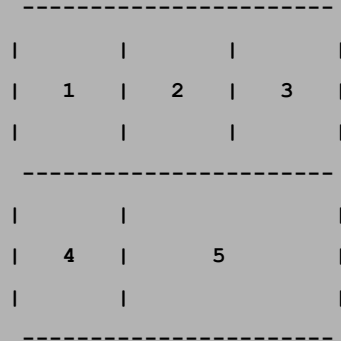

```

* The face between 1 & 4 is local-one-to-one. The face between
* 5 and (2 & 3) is local one-to-many.
*/

```

```

INTEGER4 FNMode = 2;

INTEGER4 TotalNumFaceNodes = 1; /* Not used for
                                * FEQuad zones*/

INTEGER4 NumConnectedBoundaryFaces = 1; /* Not used for
                                * FEQuad zones*/

INTEGER4 TotalNumBoundaryConnections = 1; /* Not used for
                                * FEQuad zones*/

INTEGER4 ShrConn = 0;

INTEGER4 ValueLocation[3] = {1,1,1}; /* Specify the variable
                                * values at the nodes.
                                * NOTE: Because all of
                                * the variables are
                                * defined at the nodes,
                                * we can just pass

```

```

* NULL for this array.
* We are providing the
* array for illustration
* purposes.
*/

I = TECZNE112("Zone 1",
              &ZoneType,
              &NumPts,
              &NumElems,
              &NumFaces,
              &ICellMax,
              &JCellMax,
              &KCellMax,
              &SolTime,
              &StrandID,
              &ParentZn,
              &IsBlock,
              &NFConns,
              &FNMode,
              &TotalNumFaceNodes,
              &NumConnectedBoundaryFaces,
              &TotalNumBoundaryConnections,
              NULL,
              ValueLocation,
              NULL,
              &ShrConn);
```

### Step 3 Define the node numbering for Zone 1

For this example, we will create 2 rectangular cells in Zone 1. Before defining your variables, you must establish a consistent node numbering scheme for your data. Once the node numbers are defined, supply the variable values in the node numbering order. In this example, Node 1 is defined

at  $X = 0$  and  $Y = 0$ . As such, the first value supplied for  $X$  (i.e.  $X[0]$ ) is 0. Similarly, the first value supplied for  $Y$  is 0.



It is important that you refer to node numbers consistently. The node numbers will be used later to define the connectivity for each element.

For this example, we will create two quadrilateral elements. The node numbering for the elements is defined in the following picture.

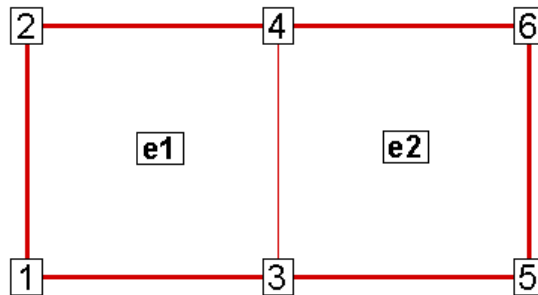

#### Step 4 Set up the variable values

The variable values will be written to the file using TECDAT. Because we are specifying nodal variables (as specified via the ValueLocation parameter in TECZNE), each variable is dimensioned by the number of points (NumPts) in the Zone. You have the option to specify some variables with nodal values and some with cell-centered values. Refer to the [Section “TECZNE112”](#) on page 53 for details.

```
float *X = new float[NumPts];
float *Y = new float[NumPts];
float *P = new float[NumPts];

/* For this example, we will create 2 rectangular cells in Zone
 * 1. Before defining your variables, you must establish a
 * consistent node numbering scheme for your data. Once the
 * node numbers are defined, supply the variable values in the
 * node numbering order. In this example, node 1 is defined at
 * X = 0 and Y = 0. As such, the first value supplied for X
```

```
* (i.e. X[0]) is 0. Similarly, the first value supplied for Y
* is 0.
*
* It is important that you refer to node numbers consistently.
* The node numbers will be used later to define the
* connectivity for each element.
*/

X[0] = 0;
X[1] = 0;
X[2] = 1;
X[3] = 1;
X[4] = 2;
X[5] = 2;

Y[0] = 0;
Y[1] = 1;
Y[2] = 0;
Y[3] = 1;
Y[4] = 0;
Y[5] = 1;

for(INTEGER4 ii=0; ii<NumPts; ii++)
    P[ii] = (float)(NumPts - ii);

INTEGER4 DIsDouble = 0; /* Set DIsDouble to zero to use
                        * variables in float format.
                        */

/* Call TECDAT once for each variable */
I = TECDAT112(&NumPts,&X[0],&DIsDouble);
```

```
I = TECDAT112 (&NumPts, &Y[0], &DIsDouble);
I = TECDAT112 (&NumPts, &P[0], &DIsDouble);
```

### Step 5 Define the connectivity list for Zone 1

The Connectivity List is used to specify the nodes that compose each element. When working with nodal variables, the numbering of the nodes is implicitly defined when the variables are declared. The first value of each variable is for node one, the second value for node two, and so on.

Because this zone contains two quadrilateral elements, we must supply 8 values in the connectivity list. The first four values define the nodes that form Element 1. Similarly, the second four values define the nodes that form Element 2.

```
INTEGER4 ConnList[8] = {1,3,4,2,
                        3,5,6,4};

I = TECNOD112 (ConnList);
```



It is important to provide the node list in either a clockwise or counter-clockwise order. Otherwise, your elements will be misshapen. For example, if the first two numbers in the above connectivity list were switched, the zone would appear as follows:

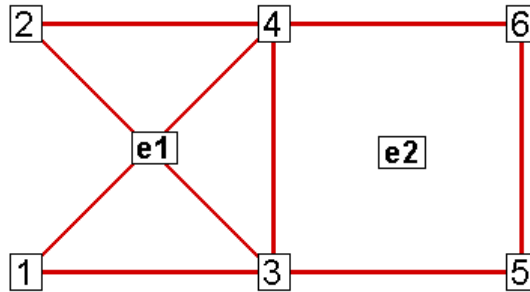

### Step 6 Define the face neighbor connections for Zone 1

Now that TECNOD has been called, the creation of Zone 1 is complete. However, in this example, we will define a face neighbor between Zone 1 and Zone 2 (to be created later in the example). Face Neighbor connections are used to define connections that are not created via the connectivity list. For example, local face neighbors may need to be defined when a zone wraps onto itself and global face neighbors may need to be defined to smooth edges across zones. Face Neighbors are used when deriving variables and drawing contours.

In this example, we are creating a face neighbor connection between Cell 2 in Zone 1 and Cell 1 in Zone 2. The information required when specifying face neighbors depends upon the type of connection. Refer to [Section “TECFACE112”](#) on page 33 for details.

In this case, we must supply the following information (in the order provided):

- the cell number in the current zone that contains the face neighbor
- the number of the face in that cell that contains the face neighbor
- the number of the other zone to which the face is connected
- the number of the cell in the other zone to which the face is connected

The face numbering for **Cell-based** finite-elements is defined using Figure 3-1 on page 35. In this example, Face 2 in Cell 2 in the current zone is connected to Cell 1 in Zone 2.

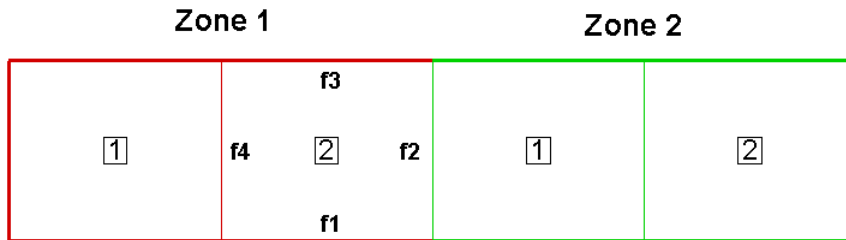

```
INTEGER4 FaceConn[4] = {2,2,2,1};
I = TECFACE112 (FaceConn);
```

### Step 7 Create Zone 2

The creation of Zone 1 is complete. We are ready to create Zone 2. For simplicity, Zone 2 is a copy of Zone 1 shifted along the X-axis. As such, many of the variables used to create Zone 1 are re-used here.

```
/* Call TECZNE to create Zone 2 */
I = TECZNE112 ("Zone 2",
              &ZoneType,
              &NumPts,
              &NumElems,
              &NumFaces,
```

```

        &ICellMax,
        &JCellMax,
        &KCellMax,
        &SolTime,
        &StrandID,
        &ParentZn,
        &IsBlock,
        &NFConns,
        &FNMode,
        &TotalNumFaceNodes,
        &NumConnectedBoundaryFaces,
        &TotalNumBoundaryConnections,
        NULL,
        ValueLocation,
        NULL,
        &ShrConn);

```

## Step 8 Define the variables for Zone 2

Because Zone 2 is a copy of Zone 1, shifted along the X-axis, we can share the Y variable definition used to Zone. We will also create a second pressure variable for Zone 2 (P2).

```

float *X2 = new float[NumPts];
float *P2 = new float[NumPts];

for(INTEGER4 ii=0; ii<NumPts; ii++)
{
    X2[ii] = X[ii] + 2;
    P2[ii] = 2 * (float)ii;
}

I = TECDAT112 (&NumPts, &X2[0], &DIsDouble);
I = TECDAT112 (&NumPts, &Y[0], &DIsDouble);
I = TECDAT112 (&NumPts, &P2[0], &DIsDouble);

```

```

delete X;
delete Y;
delete P;
delete X2;
delete P2;

```

### Step 9 Define the connectivity list for Zone 2

As with Zone 1, we must define the connectivity list for Zone 2. Because, the node numbering restarts at one for each new zone and the nodal arrangement is identical between the two zones, we may reuse the connectivity list from Zone 1.

```
I = TECNOD112 (ConnList);
```

### Step 10 Define the face neighbor connections for Zone 2

We will now specify the face neighbor connection with respect to our new current zone of Zone 2.

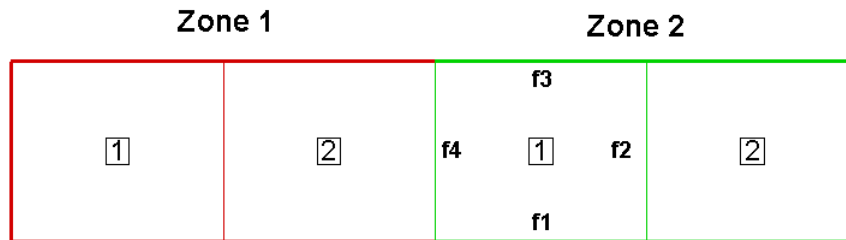

```

INTEGER4 FaceConn2[4] = {1,4,1,2}; /* cell 1, face 4 in
* current zone is a
* neighbor to cell 2 in
* zone 1.
*/

I = TECFACE112 (FaceConn2);

```

---

## Step 11 Close the file

Call TECEND to close the file.

```
I = TECEND112 ();
```

### Summary

When the preceding code is compiled and built, the data file will look as follows (with the Mesh and Edge layers turned-on):

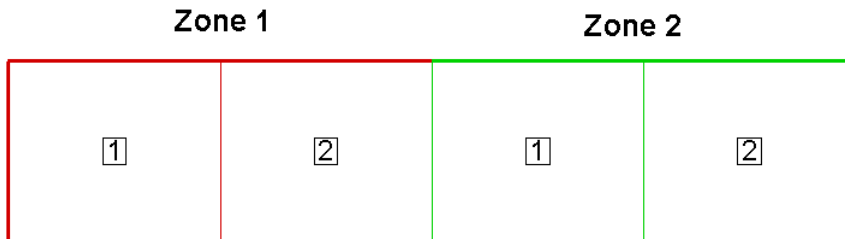

With the Mesh layer deactivated, the data set will look as follows:

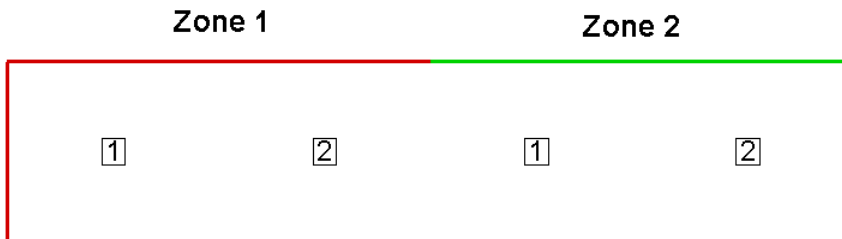

If we had not included face neighbor connections, an Edge line would be drawn in between the two zones.

### 3- 9.2 Polygonal Example

The following example (written in C++) illustrates how to create a single octagonal cell using the TecIO library.

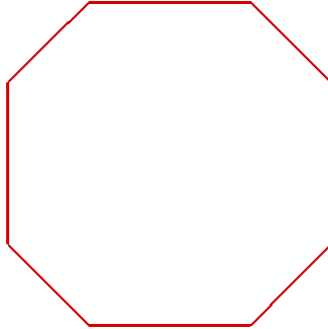

In order to keep the example as simple as possible, error checking is not included. If you plan to compile this example, be sure to include TECIO.h. The source files for this example can be downloaded separately as part of the TecIO package at [www.tecplot.com](http://www.tecplot.com), in `\util\tecioexamples\octagon`. TECIO.h is included in your `\include` folder.

For complete details on the parameters used and the function syntax for each TecIO function, refer to [Section 3 - 7 “Binary Data File Function Reference”](#). When creating a binary data file using the TecIO library, the functions must be called in a specific order. Refer to [Section 3 - 4 “Binary Data File Function Calling Sequence”](#) for details.

#### Step 1 Initialize the data file using TECINI

TECINI is required for all data files. It is used to: open the data file and initialize the file header information (name the data file, the variables for the data file, and the file type).

```
INTEGER4 Debug      = 1;
INTEGER4 VIsDouble  = 0;
INTEGER4 FileType   = 0;
INTEGER4 I;         /* used to check return codes */

/*
 * Open the file and write the Tecplot datafile
 * header information
 */
```

```

I = TECINI112("Octagon",
             "X Y P", /* Defines the variables for the data
                       * file. Each zone must contain each
                       * of the vars listed here. The order
                       * of the variables in the list is
                       * used to define the variable number
                       * (e.g. X is Variable 1). When
                       * referring to variables in other
                       * TecIO functions, you will refer to
                       * thevariable by its number.
                       */
             "Octagon.plt",
             ".", /* scratch directory */
             &FileType,
             &Debug,
             &VIsDouble);

```

## Step 2 Create Zone 1

After TECINI is called, call TECZNE to create one or more zones for your data file.

```

/* In this example, we will create a single octagonal cell in
 * Tecplot 360's polyhedral file format.
 */
INTEGER4 ZoneType = 6; /* FEPolygon */
INTEGER4 NumNodes = 8; /* Number of nodes in the octagon.*/
INTEGER4 NumElems = 1; /* Number of octagonal elements. */
INTEGER4 NumFaces = 8; /* Number of faces in the octagon.*/
INTEGER4 ICellMax = 0; /* Not Used */
INTEGER4 JCellMax = 0; /* Not Used */
INTEGER4 KCellMax = 0; /* Not Used */
double SolTime = 360.0;
INTEGER4 StrandID = 0; /* Static Zone */
INTEGER4 ParentZn = 0; /* No Parent Zone */

```

```
INTEGER4 IsBlock   = 1;    /* Block */
INTEGER4 NFConns   = 0;
INTEGER4 FNMode    = 0;

/* For polygonal zones, the total number of face nodes is equal
 * to twice the number of nodes. This is because, each face
 * has exactly two nodes.
 */
INTEGER4 NumFaceNodes = 2 * NumNodes;
/* Boundary Faces and Boundary Connections are not used in this
 * example.
 */
INTEGER4 NumBFaces   = 0;
INTEGER4 NumBConnections = 0;

INTEGER4 ShrConn     = 0;

I = TECZNE112("Octagonal Zone",
             &ZoneType,
             &NumNodes,
             &NumElems,
             &NumFaces,
             &ICellMax,
             &JCellMax,
             &KCellMax,
             &SolTime,
             &StrandID,
             &ParentZn,
             &IsBlock,
             &NFConns,
             &FNMode,
```

```

&NumFaceNodes ,
&NumBFaces ,
&NumBConnections ,
NULL ,
NULL, /* When Value Location is not specified,
      * Tecplot will treat all variables as
      * nodal variables.
      */
NULL ,
&ShrConn) ;

```

### Step 3 Define node numbering

For this example, we will create a single octagonal cell. Before defining your variables, you must establish a consistent node numbering scheme for your data. Once the node numbers are defined, supply the variable values in the node numbering order. In this example, Node 1 is defined at  $X = .25$  and  $Y = 0$ . As such, the first value supplied for  $X$  (i.e.  $X[0]$ ) is  $.25$ . Similarly, the first value supplied for  $Y$  is  $0$ .

It is important that you refer to node numbers consistently. The node numbers will be used later to define the connectivity for each element.

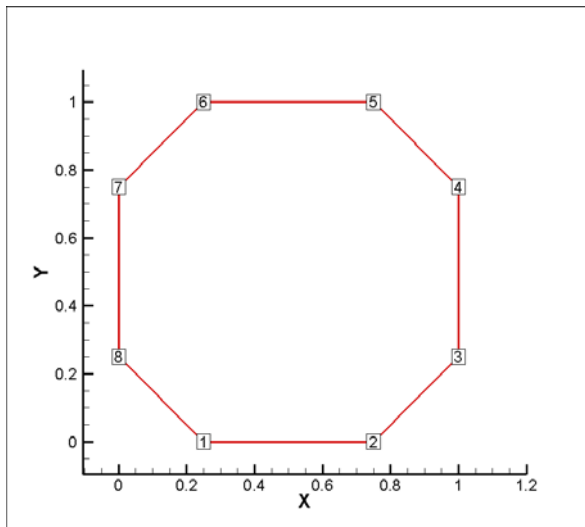

## Step 4 Set up the variable values

Write the variable values to the file using TECDAT. Because we are specifying nodal variables (as specified via the ValueLocation parameter in TECZNE), each variable is dimensioned by the number of points (NumPts) in the Zone. You have the option to specify some variables with nodal values and some with cell-centered values. Refer to [Section “TECZNE112”](#) on page 53 for details.

The order of the values supplied for each nodal variable is determined by the node numbering established in Step 3. The first value for each variable is for Node 1, the second value for each variable is for Node 2 and so forth.

$V1 = \{ValueAtNode1, ValueAtNode2, \dots, ValueAtNodeN\}$

where  $N$  is the total number of nodes

```
float *X = new float[NumNodes];
float *Y = new float[NumNodes];
float *P = new float[NumNodes];

//Define the grid values.
X[0] = 0.25;
Y[0] = 0.0;

X[1] = 0.75;
Y[1] = 0.0;

X[2] = 1.0;
Y[2] = 0.25;

X[3] = 1.0;
Y[3] = 0.75;

X[4] = 0.75;
Y[4] = 1.0;

X[5] = 0.25;
Y[5] = 1.0;
```

```
X[6] = 0.0;
Y[6] = 0.75;

X[7] = 0.0;
Y[7] = 0.25;

for (INTEGER4 ii = 0; ii < 8; ii++)
    P[ii] = .5;

/* Write out the field data using TECDAT */
INTEGER4 DIsDouble = 0; /* set IsDouble to 0 to use float
                        * variables. */

I = TECDAT112(&NumNodes, X, &DIsDouble);
I = TECDAT112(&NumNodes, Y, &DIsDouble);
I = TECDAT112(&NumNodes, P, &DIsDouble);

delete X;
delete Y;
delete P;
```

## Step 5 Define the Face Nodes

The FaceNodes array is used to indicate which nodes define which face. As mentioned earlier, the number of the nodes is implicitly defined by the order in which the nodal data is provided. The first value of each nodal variable describes Node 1, the second value describes Node 2, and so on.

The face numbering is also implicitly defined. Because there are two nodes in each face of any polygonal zone, the first two nodes provided define Face 1, the next two define Face 2 and so on. If there was a variable number of nodes used to define the faces, the array would be more complicated. Refer to [Section 3- 9.4 “Multiple Polygonal Zones”](#) for an example.

The following picture describes the face numbering for this example:

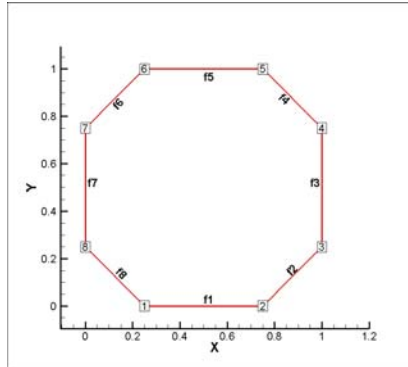

As you can see, Face 1 is defined by Nodes 1 and 2, Face 2 is defined by Nodes 2 and 3, and so forth. Because of this simple arrangement, we can use a for-loop to define all but the end points of the face nodes array.

```

INTEGER4 *FaceNodes = new INTEGER4[NumFaceNodes];

/*
 * Loop over number of sides, and set each side to two
 * consecutive nodes.
 */
for ( INTEGER4 ii = 0; ii < 8; ii++ )
{
    FaceNodes[2*ii] = ii+1;
    FaceNodes[2*ii+1] = ii+2;
}
FaceNodes[15] = 1;

```

### Step 6 Define the right and left elements of each face

The last step for writing out the polygonal data is to define the right and left neighboring elements for each face. The neighboring elements can be determined using the right-hand rule. For each face, place your right-hand along the face with your fingers pointing the direction of incrementing node numbers (i.e. from Node 1 to Node 2). The right side of your hand will indicate the right element, and the left side of your hand will indicate the left element. Refer to [Section 3- 8.3 “FaceRight-Elms and FaceLeftElms”](#) for details.

The number zero is used to indicate that there isn't an element on that side of the face (i.e. the face is on the edge of the data set). This is referred to as “no neighboring element”.

Because of the way we numbered the nodes and faces, the right element for every face is the element itself (Element 1) and the left element is "no-neighboring element" (Element 0).

```

INTEGER4 *FaceLeftElems = new INTEGER4 [NumFaces];
INTEGER4 *FaceRightElems = new INTEGER4 [NumFaces];

for (INTEGER4 ii = 0; ii < NumFaces; ii++)
{
    FaceLeftElems[ii] = 0;
    FaceRightElems[ii] = 1;
}

```

### Step 7 Close the file

Call TECEND to close the file.

```
I = TECEND112 ();
```

## 3- 9.3 Multiple Polyhedral Zones

The following example demonstrates how to create two polyhedral zones, a rectangular solid and a prism. The resulting image is a three-dimensional arrow (shown below).

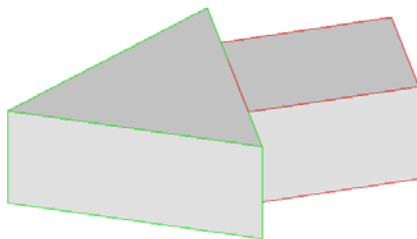

This example covers the following topics: polyhedral data, working with multiple zones, and specifying partially obscured faces. In order to keep the example as simple as possible, error checking is not included. If you plan to compile this example, be sure to include: *TECIO.h*. The source files for this example are downloadable in the TecIO package from [www.tecplot.com](http://www.tecplot.com), in *util\tecioexamples\arrow*.

For complete details on the parameters used and the function syntax for each TecIO function, refer to [Section 3 - 7 “Binary Data File Function Reference”](#). When creating a binary data file using the

TecIO library, the functions must be called in a specific order. Refer to [Section 3 - 4 “Binary Data File Function Calling Sequence”](#) for details.

## Step 1 Initialize the data file using TECINI

TECINI is required for all data files. This function opens the data file and initializes the file header information (names the data file, the variables for the data file, and the file type)

```
INTEGER4 Debug      = 1;
INTEGER4 VIsDouble = 1;
INTEGER4 FileType  = 0;
INTEGER4 I;

/* Open the file and write the Tecplot datafile
 * header information
 */
I = TECINI112("Multiple polyhedral zones", /* Name of the entire
                                           * dataset.
                                           */
             "X Y Z P", /* Defines the variables for the data
                           * file. Each zone must contain each of
                           * the variables listed here. The order
                           * of the variables in the list is used
                           * to define the variable number (e.g.
                           * X is Var 1).
                           */
             "Arrow.plt",
             ".", /* Scratch Directory */
             &FileType,
             &Debug,
             &VIsDouble);
```

## Step 2 Create Zone 1 (rectangle)

After TECINI is called, call TECZNE to create one or more zones for your data file. In this example, Zone 1 contains a single rectangular solid created as a face-based finite element (i.e. polyhedral zone). The zone has eight points (or nodes), six faces and one element.

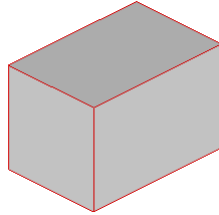

```

/* TECZNE Parameters */
INTEGER4 ZoneType           = 7; /* sets the zone type
                                * to polyhedral */

INTEGER4 NumPts_Rect       = 8;
INTEGER4 NumElems_Rect     = 1;
INTEGER4 NumFaces_Rect    = 6;
INTEGER4 ICellMax          = 0; /* not used */
INTEGER4 JCellMax          = 0; /* not used */
INTEGER4 KCellMax          = 0; /* not used */
double   SolutionTime      = 0.0;
INTEGER4 StrandID         = 0;
INTEGER4 ParentZone       = 0;
INTEGER4 IsBlock          = 1;
INTEGER4 NumFaceConnections = 0; /* not used */
INTEGER4 FaceNeighborMode = 1; /* not used */
INTEGER4 SharConn         = 0;

/* In a rectangular solid, each face is composed of four nodes.
 * As such, the total number of face nodes is twenty-four (four
 * nodes for each of the six faces).
 */

```

```
INTEGER4 TotalNumFaceNodes_Rect      = 24;

/* There is one connected boundary face in this zone (the face on
 * the rectangle adjacent to the arrowhead). Refer to the Data
 * Format Guide for additional information. */
INTEGER4 NumConnBndryFaces_Rect      = 1;

/* The connected boundary face has one connection, the face on
 * the bottom of the arrowhead. A connection is an element-zone
 * tuple that indicates a neighboring element (and its zone) when
 * the neighboring element is in a different zone. Generally,
 * there will be one boundary connection for each boundary face.
 */
INTEGER4 TotalNumBndryConns_Rect     = 1;

/* For illustrative purposes, the grid variables (X, Y, and Z)
 * are nodal variables (i.e. ValueLocation = 1), and the pressure
 * variable (P) is a cell-centered variable (i.e.
 * ValueLocation = 0).
 */
INTEGER4 ValueLocation[4] = { 1, 1, 1, 0 };

I = TECZNE112("Zone 1: Rectangular Solid",
              &ZoneType,
              &NumPts_Rect,
              &NumElems_Rect,
              &NumFaces_Rect,
              &ICellMax,
              &JCellMax,
              &KCellMax,
              &SolutionTime,
              &StrandID,
```

```
&ParentZone,  
&IsBlock,  
&NumFaceConnections,  
&FaceNeighborMode,  
&TotalNumFaceNodes_Rect,  
&NumConnBndryFaces_Rect,  
&TotalNumBndryConns_Rect,  
NULL,  
ValueLocation,  
NULL,  
&SharConn);
```

### Step 3 Set variable values for Zone 1 (rectangle)

Now that the zone has been created, write the variable values to the file by calling TECDAT. While there are more elegant ways to define the grid coordinates for the rectangle, the values are defined explicitly for simplicity.

Using the picture below, define the variable values.

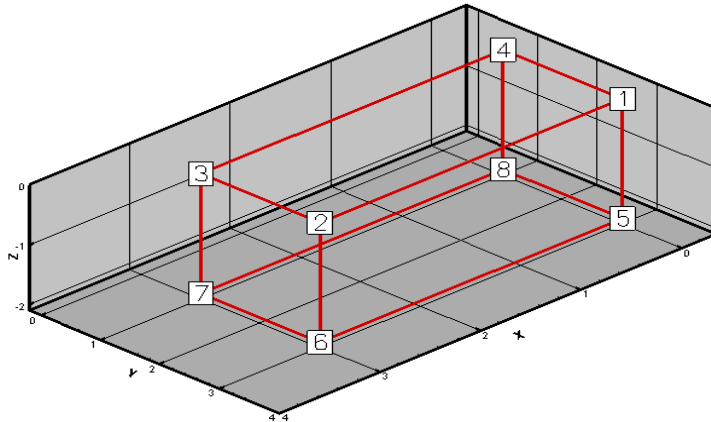

For nodal variables, provide the values for each variable in nodal order. Similarly, for cell-centered values, provide the variable values in cell order. The location of each variable is specified with TECZNE.

```
//set variable values (X_Rect, Y_Rect, Z_Rect & P_Rect)
double *X_Rect = new double[NumPts_Rect];
double *Y_Rect = new double[NumPts_Rect];
double *Z_Rect = new double[NumPts_Rect];
double *P_Rect = new double[NumElems_Rect];

for(INTEGER4 ii = 0; ii <= NumPts_Rect/2; ii+= 4)
{
    X_Rect[ii] = 0;
    X_Rect[ii+1] = 3;
    X_Rect[ii+2] = 3;
    X_Rect[ii+3] = 0;

    Y_Rect[ii] = 3;
    Y_Rect[ii+1] = 3;
    Y_Rect[ii+2] = 1;
    Y_Rect[ii+3] = 1;
}

for(INTEGER4 ii = 0; ii<4; ii++)
    Z_Rect[ii] = 0;

for(INTEGER4 ii = 4; ii <NumPts_Rect; ii++)
    Z_Rect[ii] = -2;

P_Rect[0] = 10;

INTEGER4 IsDouble = 1;
```

```

I = TECDAT112 (&NumPts_Rect, X_Rect, &IsDouble);
I = TECDAT112 (&NumPts_Rect, Y_Rect, &IsDouble);
I = TECDAT112 (&NumPts_Rect, Z_Rect, &IsDouble);
I = TECDAT112 (&NumElems_Rect, P_Rect, &IsDouble);

```

#### Step 4 Define the facemap data for Zone 1

Using the following figure, specify which nodes define which face.

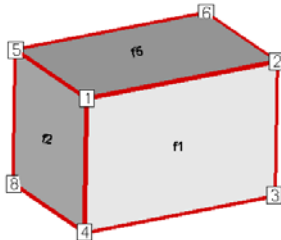

Figure 3-3. Zone 2 of the sample data. Node 7 is obscured from view and located in the back-left hand corner. Face 6 is the bottom face. Face 3 is opposite Face 1 and Face 4 is

In order to specify the face map data, you must first specify how many nodes are in each face using the FaceNodeCounts array. After defining the FaceNodeCounts array, use the FaceNodes array to identify the nodes that compose each face. Refer to [Section 3- 8.2 “FaceNodeCounts and FaceNodes”](#) for additional information.

```

/* The FaceNodeCounts array is used to describe the number of
 * nodes in each face of the zone. The first value in the array
 * is the number of nodes in Face 1, the second value is the
 * number of nodes in Face 2 and so forth. In this example, each
 * face of the zone has four nodes.
 */

INTEGER4 *FaceNodeCounts_Rect = new INTEGER4 [NumFaces_Rect];
//For this particular zone, each face has the 4 nodes
for (INTEGER4 ii=0;ii<NumFaces_Rect;ii++)
    FaceNodeCounts_Rect [ii] = 4;

```

```
/* The FaceNodes array is used to specify the nodes that compose
 * each face. For each face (n of N), the number of nodes used
 * to define the face is specified by the nth value in the
 * FaceNodeCounts array. For example, if the first value in the
 * FaceNodeCounts array is 4 (indicating Face 1 is composed of
 * four nodes), the first four values in the FaceNodes array are
 * the node numbers of the nodes in Face 1.
 *
 * -----
 * WARNING
 * When providing the node numbers for each face, you must
 * provide the node numbers in a consistent order (either
 * clockwise or counter-clockwise. Providing the node numbers
 * out of order results in contorted faces.
 * -----
 */

INTEGER4 *FaceNodes_Rect = new INTEGER4[TotalNumFaceNodes_Rect];

//Nodes for Face 1
FaceNodes_Rect[0] = 1;
FaceNodes_Rect[1] = 2;
FaceNodes_Rect[2] = 3;
FaceNodes_Rect[3] = 4;

//Nodes for Face 2
FaceNodes_Rect[4] = 1;
FaceNodes_Rect[5] = 4;
FaceNodes_Rect[6] = 8;
FaceNodes_Rect[7] = 5;
```

```
//Nodes for Face 3
FaceNodes_Rect[8] = 5;
FaceNodes_Rect[9] = 8;
FaceNodes_Rect[10] = 7;
FaceNodes_Rect[11] = 6;

//Nodes for Face 4
FaceNodes_Rect[12] = 2;
FaceNodes_Rect[13] = 6;
FaceNodes_Rect[14] = 7;
FaceNodes_Rect[15] = 3;

//Nodes for Face 5
FaceNodes_Rect[16] = 6;
FaceNodes_Rect[17] = 2;
FaceNodes_Rect[18] = 1;
FaceNodes_Rect[19] = 5;

//Nodes for Face 6
FaceNodes_Rect[20] = 3;
FaceNodes_Rect[21] = 7;
FaceNodes_Rect[22] = 8;
FaceNodes_Rect[23] = 4;
```



When providing the node numbers for each face, you must provide the node numbers in a consistent order (either clockwise or counter-clockwise). Providing the node numbers out of order results in contorted faces.

## Step 5 Specify the neighboring elements for Zone 1

The next step for writing out the polyhedral data is to define the right and left neighboring elements for each face. The neighboring elements can be determined using the right-hand rule. For each face, place your right-hand along the face with your fingers pointing the direction of incrementing node numbers (i.e. from Node 1 to Node 2). The right side of your hand will indicate the right element, and the left side of your hand will indicate the left element. Refer to [Section 3- 8.3 “FaceRightElems and FaceLeftElems”](#) for details.

The number zero is used to indicate that there isn't an element on that side of the face. A negative number is used when the neighboring element is in another zone. The value of the negative number along with the FaceBndryConnectionCounts array points to the position in the FaceBoundaryConnectionElems and FaceBoundaryConnectionZones arrays that defines the element and zone numbers of the neighboring element. Refer to Step 6 for details.

Because of the way we numbered the nodes and faces, the right element for every face (except the face connected to the arrowhead) is the element itself (Element 1) and the left element is "no-neighboring element" (Element 0).

```

INTEGER4 *FaceLeftElems_Rect = new INTEGER4[NumFaces_Rect];
INTEGER4 *FaceRightElems_Rect = new INTEGER4[NumFaces_Rect];

/* Since this zone has just one element, all leftelems are
 * NoNeighboring Element and all right elems are itself
 */
for(INTEGER4 ii=0;ii<NumFaces_Rect;ii++)
{
    FaceRightElems_Rect[ii] = 1;
    FaceLeftElems_Rect[ii] = 0;
}

/* The negative value in the FaceLeftElems array indicates that
 * the face is connected to an element in another zone. In this
 * case, Face 4 is connected to a face in Zone 2 (to be defined
 * later in the example). The FaceBoundaryConnectionElems array
 * lists all of the element numbers in other zones that the
 * current zone shares boundary connections with. Similarly, the
 * FaceBoundaryConnectionZones array lists all of the zone
numbers
 * with which the current zone shares boundaries. A negative

```

```

* value in the FaceLeftElems or FaceRightElems array indicates
* the position within these arrays that defines the neighboring
* element and zone for a face.
*
* For example, if the FaceBoundaryConnectionElems array is:
* [1 8 2] and the FaceBoundaryConnectionZones array is: [2 5 3],
* a FaceLeftElems or FaceRightElems value of -2 indicates that
* the face in question has a boundary connection with Element 8
* in Zone 5.
*/
FaceLeftElems_Rect[3]    = -1;

```

### Step 6 Define boundary connections for Zone 1

The last step for defining the rectangular solid is to describe the boundary connections and call TECPOLY.

```

/* The FaceBndryConnectionCounts array is used to define the
* number of boundary connections for each face that has a
* boundary connection. For example, if a zone has three boundary
* connections in total (NumConnectedBoundaryFaces), two of those
* boundary connections are in one face, and the remaining
* boundary connection is in a second face, the
* FaceBndryConnectionCounts array would be: [2 1].
* In this example, the total number of connected boundary faces
* (specified via TECZNE) is equal to one, so the
* FaceBoundaryConnectionCounts array contains a single value
(1).
*/
INTEGER4 *FaceBndryConnCounts_Rect = new
INTEGER4[NumConnBndryFaces_Rect];
FaceBndryConnCounts_Rect[0] = 1;

/* The value(s) in the FaceBndryConnectionElems and
* FaceBndryConnectionZones arrays specify the element number and

```

```
    * zone number, respectively, that a given boundary connection is
    * connected to. In this case, the boundary connection face is
    * connected to Element 1 in Zone 2.
    */
    INTEGER4 *FaceBndryConnElems_Rect = new
    INTEGER4[TotalNumBndryConns_ReCt];

    INTEGER4 *FaceBndryConnZones_Rect = new
    INTEGER4[TotalNumBndryConns_ReCt];

    FaceBndryConnElems_Rect[0] = 1;
    FaceBndryConnZones_Rect[0] = 2;

    I = TECPOLY112(FaceNodeCounts_Rect,
                  FaceNodes_Rect,
                  FaceLeftElems_Rect,
                  FaceRightElems_Rect,
                  FaceBndryConnCounts_Rect,
                  FaceBndryConnElems_Rect,
                  FaceBndryConnZones_Rect);

    /* cleanup */
    delete X_Rect;
    delete Y_Rect;
    delete Z_Rect;
    delete P_Rect;
    delete FaceNodeCounts_Rect;
    delete FaceNodes_Rect;
    delete FaceLeftElems_Rect;
    delete FaceRightElems_Rect;
    delete FaceBndryConnCounts_Rect;
    delete FaceBndryConnElems_Rect;
    delete FaceBndryConnZones_Rect;
```

## Step 7 Create Zone 2

The data for Zone 1 has been written to the data file, so we are ready to create Zone 2. For simplicity, we will reuse many of the variables from that are not relevant to this tutorial.

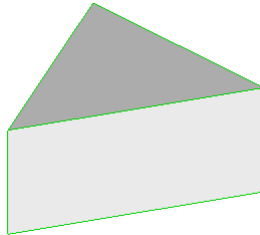

Zone 2 (the arrowhead or prism) has a single element composed of six nodes and five faces.

```
//TECZNE Parameters
INTEGER4 NumPts_Prism           = 6;
INTEGER4 NumElems_Prism         = 1;
INTEGER4 NumFaces_Prism         = 5;

/* The prism is composed of two triangular faces and three
 * rectangular faces. The total number of face nodes is the sum
 * of the nodes in each triangular face (2 times 3) and the nodes
 * in each rectangular face (3 times 4).
 */
INTEGER4 TotalNumFaceNodes_Prism = 18;

/* As with Zone 1, Zone 2 has one connected boundary face, the
 * face that is connected to Zone 1.
 */
INTEGER4 NumConnBndryFaces_Prism = 1;

/* In this case, we have set the total number of boundary
 * connections for the connected face to two. The first boundary
 * connection is the connection to Zone 1. The second boundary
```

```
* connection is used to indicate that the face is only partially
* obscured by the face from Zone 1. If we omitted the second
* boundary connection, the connected face of the prism would
* disappear if the rectangular zone was deactivated.
*/
INTEGER4 TotalNumBndryConns_Prism = 2;

I = TECZNE112("Zone 2: Prism",
             &ZoneType,
             &NumPts_Prism,
             &NumElems_Prism,
             &NumFaces_Prism,
             &ICellMax,
             &JCellMax,
             &KCellMax,
             &SolutionTime,
             &StrandID,
             &ParentZone,
             &IsBlock,
             &NumFaceConnections,
             &FaceNeighborMode,
             &TotalNumFaceNodes_Prism,
             &NumConnBndryFaces_Prism,
             &TotalNumBndryConns_Prism,
             NULL,
             ValueLocation,
             NULL,
             &SharConn);
```

### Step 8 Specify the variable values for Zone 2

Now that the zone has been created, we must write the variable values to the file by calling TECDAT. While there are more elegant ways to define the grid coordinates for the prism, the values are defined explicitly in order to keep the example relatively simple.

Using the picture below, define the variable values.

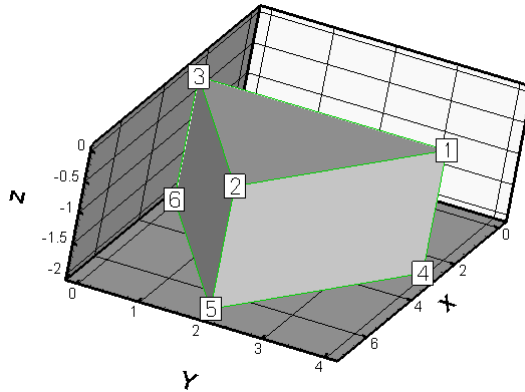

```
double *X_Prism = new double[NumPts_Prism];
double *Y_Prism = new double[NumPts_Prism];
double *Z_Prism = new double[NumPts_Prism];

/* Set the X and Y variable values, one z-plane at a time */
double ZVal = 0;
for(INTEGER4 ii = 0; ii < 2; ii++)
{
    // triangle in Z=ZVal plane
    X_Prism[3*ii] = 3;
    Y_Prism[3*ii] = 4;
    Z_Prism[3*ii] = ZVal;

    X_Prism[3*ii+1] = 7;
    Y_Prism[3*ii+1] = 2;
    Z_Prism[3*ii+1] = ZVal;
}
```

```
        X_Prism[3*ii+2] = 3;
        Y_Prism[3*ii+2] = 0;
        Z_Prism[3*ii+2] = ZVal;

        ZVal = ZVal - 2;
    }

    /* When we called TecZne, we specified that the variable 4
    * (pressure) is cell-centered. As such, only NumElements number
    * of values needs to be written to the data file for the pressure
    * variable.
    */
    double *P_Prism = new double[NumElems_Prism];
    P_Prism[0] = 20;

    I = TECDAT112(&NumPts_Prism, X_Prism, &IsDouble);
    I = TECDAT112(&NumPts_Prism, Y_Prism, &IsDouble);
    I = TECDAT112(&NumPts_Prism, Z_Prism, &IsDouble);
    I = TECDAT112(&NumElems_Prism,P_Prism, &IsDouble);
```

## Step 9 Define the face map for the arrowhead

Before creating the data set, we have defined the node numbers, face numbers and element numbers. Using the following figure, specify the nodes that define each face.

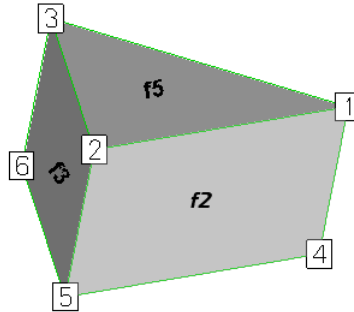

Figure 3-4. The arrowhead with three faces visible (Face 2, Face 3 and Face 5). The remaining rectangular face is Face 1, and the remaining triangular face is Face 4).

The faces are created from the data file format using the FaceNodeCounts and FaceNodes array. The FaceNodeCounts array specifies the number of nodes contained in each face. The first value in the array is the number of nodes in Face 1, followed by the number of nodes in Face 2, and so forth. The FaceNodes array lists the node numbers in each face. The FaceNodes array first lists all of the nodes in Face 1, followed by all of the nodes in Face 2, and so forth.

In this example, Face 1 is composed of four nodes (Node 1, Node 3, Node 6 and Node 4). As such, the first value in the FaceNodeCounts array is “4” and the first four values in the FaceNodes array are [1, 3, 6, 4].

```

INTEGER4 *FaceNodeCounts_Prism = new INTEGER4 [NumFaces_Prism];
INTEGER4 *FaceNodes_Prism      = new
INTEGER4 [TotalNumFaceNodes_Prism];

/* Because of the way we chose to number our faces, the first
 * three faces are rectangular and the last two are triangular.
 * The numbering of the faces is arbitrary, but the faces must
 * be referred to consistently.
 */
for(INTEGER4 ii=0;ii<3;ii++)

```

```
    FaceNodeCounts_Prism[ii] = 4;

    for(INTEGER4 ii=3;ii<NumFaces_Prism;ii++)
        FaceNodeCounts_Prism[ii] = 3;

//Nodes for Face 1
FaceNodes_Prism[0] = 1;
FaceNodes_Prism[1] = 3;
FaceNodes_Prism[2] = 6;
FaceNodes_Prism[3] = 4;

//Nodes for Face 2
FaceNodes_Prism[4] = 1;
FaceNodes_Prism[5] = 4;
FaceNodes_Prism[6] = 5;
FaceNodes_Prism[7] = 2;

//Nodes for Face 3
FaceNodes_Prism[8] = 3;
FaceNodes_Prism[9] = 2;
FaceNodes_Prism[10] = 5;
FaceNodes_Prism[11] = 6;

//Nodes for Face 4
FaceNodes_Prism[12] = 5;
FaceNodes_Prism[13] = 4;
FaceNodes_Prism[14] = 6;

//Nodes for Face 5
FaceNodes_Prism[15] = 1;
FaceNodes_Prism[16] = 2;
FaceNodes_Prism[17] = 3;
```

## Step 10 Specify the neighboring elements for Zone 2

Now that we have defined the nodes that compose each face, we must specify the element on either side of each face. The neighboring elements can be determined using the right-hand rule. For each face, place your right-hand along the face with your fingers pointing the direction of incrementing node numbers (i.e. from Node 1 to Node 2). The right side of your hand will indicate the right element, and the left side of your hand will indicate the left element. Refer to [Section 3- 8.3 “FaceRightElems and FaceLeftElems”](#) for details.

The number zero is used to indicate that there isn't an element on that side of the face. A negative number is used when the neighboring element is in another zone. The value of the negative number points to the position in the FaceBoundaryConnectionElems and FaceBoundaryConnectionZones arrays that defines the element and zone numbers of the neighboring element. Refer to Step 11 for details.

Because of the way we numbered the nodes and faces, the right element for every face (except the face connected to the rectangular solid) is the element itself (Element 1) and the left element is "no-neighboring element" (Element 0).

```

/* Since this zone has just one element, all leftelems are
 * NoNeighboring Element and all right elems are itself.
 */
INTEGER4 *FaceLeftElems_Prism = new INTEGER4[NumFaces_Prism];
INTEGER4 *FaceRightElems_Prism = new INTEGER4[NumFaces_Prism];

for(INTEGER4 ii=0;ii<NumFaces_Prism;ii++)
{
    FaceRightElems_Prism[ii] = 1;
    FaceLeftElems_Prism[ii] = 0;
}

/* The negative value in the FaceLeftElems array indicates that
 * the face is connected to an element in another zone. In this
 * case, Face 1 is connected to a face in Zone 1 (as indicated in
 * Line 6). The FaceBoundaryConnectionElems array lists all of
 * the element numbers in other zones that the current zone shares
 * boundary connections with. Similarly, the
 * FaceBoundaryConnectionZones array lists all of the zone
 * numbers
 * with which the current zone shares boundaries. A negative

```

```

* value in the FaceLeftElems or FaceRightElems array indicates
* the position within these arrays that defines the neighboring
* element and zone for a face.
*/
FaceLeftElems_Prism[0] = -1;

```

## Step 11 Specify boundary connections for Zone 2

The last step for creating Zone 2 is to specify the boundary connections.

```

INTEGER4 *FaceBndryConnCounts_Prism = new
INTEGER4[NumConnBndryFaces_Prism];

FaceBndryConnCounts_Prism[0] = 2;

INTEGER4 *FaceBndryConnElems_Prism = new
INTEGER4[TotalNumBndryConns_Prism];

INTEGER4 *FaceBndryConnZones_Prism = new
INTEGER4[TotalNumBndryConns_Prism];

/* As previously mentioned, a connected boundary face is a face
* that has either multiple neighboring faces or neighbor(s) that
* belong to another zone. Those cases are sufficient when the
* combination of all of the face's neighbors completely cover the
* face. However, there are some cases (such as the bottom of the
* arrowhead) where the face is not completely covered by its
* neighbors. In those cases the face is referred to as ipartially
* obscuredî. A partially obscured face is indicated by
* incrementing the value in TotalNumConnectedBoundaryFaces and
* entering a value of 0 in both the FaceBndryConnectionElems and
* FaceBoundaryConnectionZones arrays for the boundary connection
* for the partially obscured face.
*/
FaceBndryConnElems_Prism[0] = 0;
FaceBndryConnZones_Prism[0] = 0;

```

```

/* Indicates that Face 1 is connected to Element 1 in Zone 1. */
FaceBndryConnElems_Prism[1] = 1;
FaceBndryConnZones_Prism[1] = 1;

I = TECPOLY112(FaceNodeCounts_Prism,
              FaceNodes_Prism,
              FaceLeftElems_Prism,
              FaceRightElems_Prism,
              FaceBndryConnCounts_Prism,
              FaceBndryConnElems_Prism,
              FaceBndryConnZones_Prism);

/* cleanup */
delete X_Prism;
delete Y_Prism;
delete Z_Prism;
delete P_Prism;
delete FaceNodeCounts_Prism;
delete FaceNodes_Prism;
delete FaceLeftElems_Prism;
delete FaceRightElems_Prism;
delete FaceBndryConnCounts_Prism;
delete FaceBndryConnElems_Prism;
delete FaceBndryConnZones_Prism;

```

### Step 12 Close the file

Call TECEND to close the file.

```
I = TECEND112 ();
```

## 3- 9.4 Multiple Polygonal Zones

The following example demonstrates how to create multiple polygonal zones. The example covers: creating a zone where each element contains a different number of nodes, boundary connections and varying variable locations (cell-centered versus nodal).

The code in this example produces the following plot:

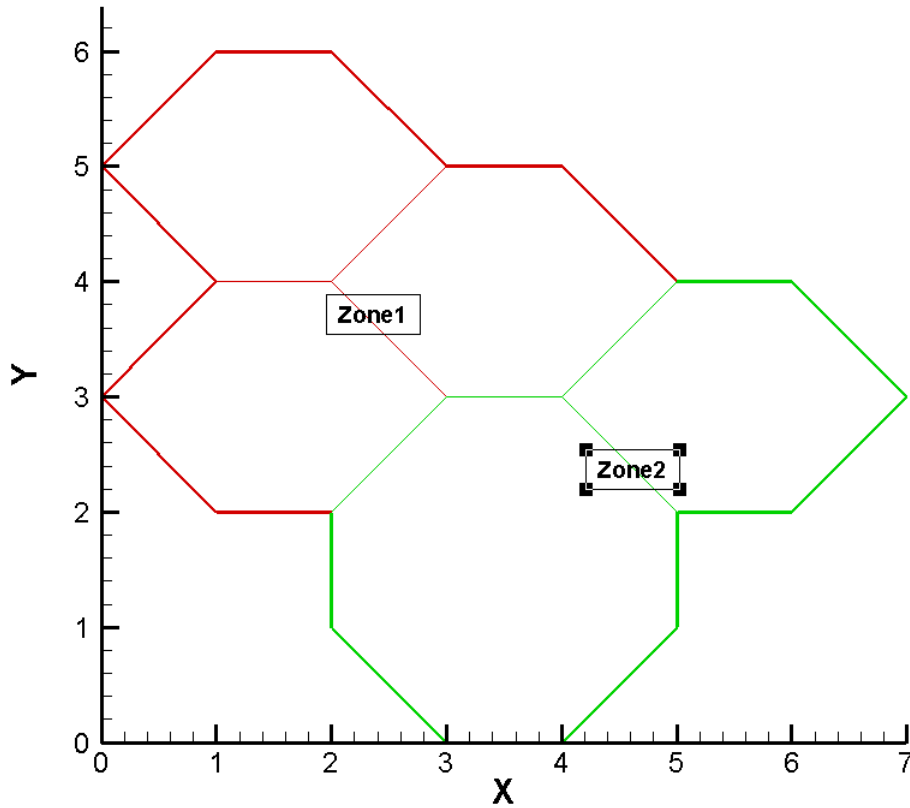

Before beginning to create a polyhedral data file, you should assign a number to each node, face, element and zone. The numbering system is used to determine the order that the information is supplied to Tecplot. You may assign any order you would like. However, once you have supplied infor-

mation to Tecplot, you cannot change the number configuration. For this example, we have selected the numbering system shown below:

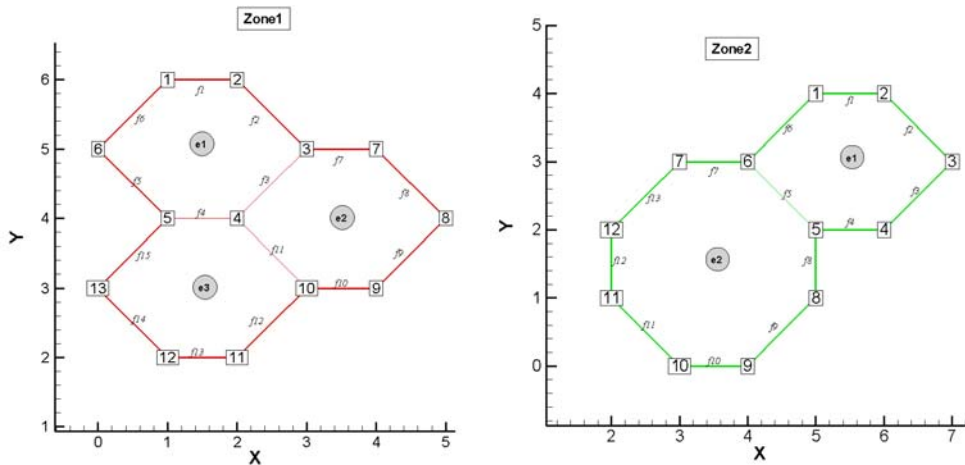

Zone 1 has a total of three elements, thirteen unique nodes and fifteen faces. Zone 2 has two elements, twelve nodes and thirteen faces.

In order to keep the example as simple as possible, error checking is not included. If you plan to compile this example, be sure to include: TECIO.h. The source files for this example are a part of the TecIO package available separately at [www.tecplot.com](http://www.tecplot.com), in `\util\tecioexamples\multiplepolygons`.

For complete details on the parameters used and the function syntax for each TecIO function, refer to [Section 3 - 7 "Binary Data File Function Reference"](#). When creating a binary data file using the TecIO library, the functions must be called in a specific order. Refer to [Section 3 - 4 "Binary Data File Function Calling Sequence"](#) for details.

## Step 1 Initialize the Data File

The first step for creating a binary data file using the TecIO library is to initialize and open the data file by calling TECINI

```

INTEGER4 I; /* use to check return values */

INTEGER4 Debug      = 1;
INTEGER4 VIsDouble = 0;
INTEGER4 FileType   = 0;

I = TECINI112("Example: Multiple polygonal zones",

```

```
"X Y P", /* Defines the variables for the data file.
        * Each zone must contain each of the vars
        * listed here. The order of the variables
        * in the list is used to define the
        * variable number (e.g. X is Variable 1).
        * When referring to variables in other
        * TecIO functions, you will refer to the
        * variable by its number.
        */
"HexagonsAndOctagon.plt",
".", /* scratch directory */
&FileType,
&Debug,
&VIsDouble);
```

## Step 2 Create Zone 1 (3 Hexagons)

The first step toward creating Zone 1 is to call TECZNE. TECZNE is used to initialize the zone and specify parameters that apply to the entire zone (e.g. number of nodes, number of elements and variable location).

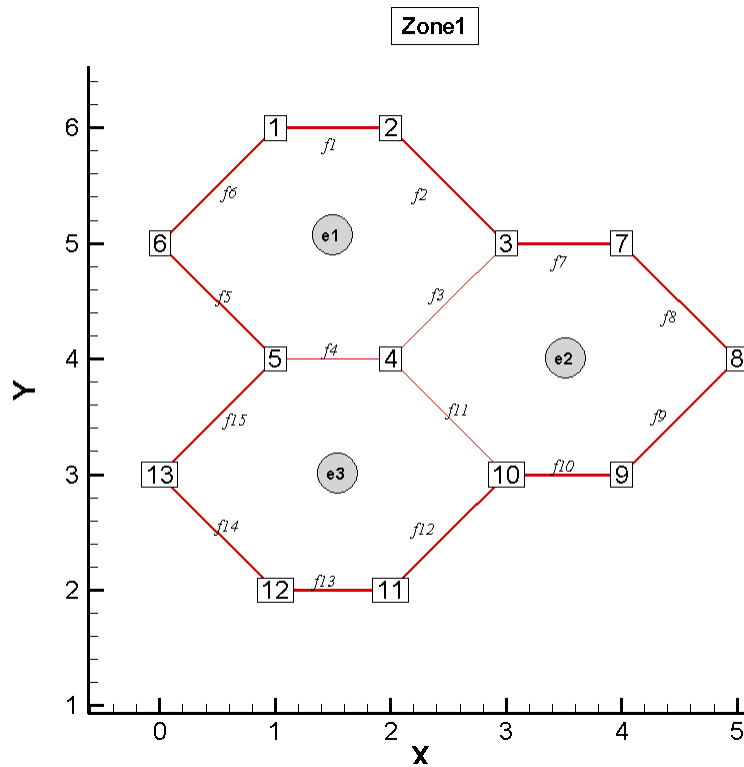

```

/* TECZNE Parameters */
INTEGER4 ZoneType           = 6; /* FE Polygon */
INTEGER4 NumPts_Z1         = 13; /* the number of unique
                                * nodes in the zone.
                                */
INTEGER4 NumElems_Z1       = 3;
INTEGER4 NumFaces_Z1       = 15; /* the number of unique
                                * faces in the zone.
                                */

```

```
INTEGER4 ICellMax      = 0;  /* not used */
INTEGER4 JCellMax      = 0;  /* not used */
INTEGER4 KCellMax      = 0;  /* not used */
double   SolutionTime  = 0.0;
INTEGER4 StrandID      = 0;
INTEGER4 ParentZone    = 0;
INTEGER4 IsBlock       = 1;
INTEGER4 NumFaceConnections = 0;
INTEGER4 FaceNeighborMode = 1;
INTEGER4 SharConn      = 0;

INTEGER4 ValueLocation[3] = { 1, 1, 0 };

/* For a polygonal zone, the total number of face nodes is
 * twice the total number of faces. This is because each face
 * is composed of exactly two nodes.
 */
INTEGER4 TotalNumFaceNodes_Z1 = 2 * NumFaces_Z1;

/* A boundary face is a face that is neighbored by an element
 * or elements in another zone or zone(s). In Zone 1, Face 9,
 * Face 10 and Face 12 have a neighbor in Zone 2. Therefore,
 * the total number of boundary faces is 3.
 */
INTEGER4 TotalNumBndryFaces_Z1 = 3;

/* Each boundary face has one or more boundary connections. A
 * boundary connection is defined as another element in another
 * zone. Face 9 has a boundary connection with Element 1 in
 * Zone 2. In this example, each boundary face is connected to
 * one other element, so the total number of boundary
 * connections is equivalent to the total number of boundary
```

```
* faces (3).
*/
INTEGER4 TotalNumBndryConns_Z1 = 3;

I = TECZNE112("Zone 1: 3 Hexagons", /* Specifies the name of
                                     * the entire dataset. When
                                     * the file is loaded into
                                     * Tecplot, the value is
                                     * available via the Data
                                     * Set Info dialog.
                                     */
             &ZoneType,
             &NumPts_Z1,
             &NumElems_Z1,
             &NumFaces_Z1,
             &ICellMax,
             &JCellMax,
             &KCellMax,
             &SolutionTime,
             &StrandID,
             &ParentZone,
             &IsBlock,
             &NumFaceConnections,
             &FaceNeighborMode,
             &TotalNumFaceNodes_Z1,
             &TotalNumBndryFaces_Z1,
             &TotalNumBndryConns_Z1,
             NULL,
             ValueLocation,
             NULL,
             &SharConn);
```

### Step 3 Specify the variable values for Zone 1

The variable values are written to the data file via the TECDAT function. For each variable you must provide either a total number of values equivalent to NumPts (if the variables are nodal) or a total number of values equivalent to NumElements (if the variables are cell-centered). The variable location is specified by the VarLocation parameter in TECZNE. In this example, X and Y are nodal variables and P is cell-centered.

The order in which the variable values must be provided is established by the numbering scheme (specified at the beginning of the example). The first value for each nodal variable (X and Y) corresponds to Node 1, the second value corresponds to Node 2 and so forth. The first value for the cell-centered value is for Element 1, the second value is for the second element or cell and so forth.

In order for the example to be easily followed, the grid coordinates are explicitly defined. When working with larger data sets, you will likely wish to use equations to define your coordinates. Refer to the picture in Step 2 for the X and Y coordinate values for Zone 1.

```
/* TECDAT Parameters */
double *X_Z1 = new double[NumPts_Z1];
double *Y_Z1 = new double[NumPts_Z1];

X_Z1[0] = 1;
Y_Z1[0] = 6;

X_Z1[1] = 2;
Y_Z1[1] = 6;

X_Z1[2] = 3;
Y_Z1[2] = 5;

X_Z1[3] = 2;
Y_Z1[3] = 4;

X_Z1[4] = 1;
Y_Z1[4] = 4;

X_Z1[5] = 0;
```

```
Y_Z1[5] = 5;

X_Z1[6] = 4;
Y_Z1[6] = 5;

X_Z1[7] = 5;
Y_Z1[7] = 4;

X_Z1[8] = 4;
Y_Z1[8] = 3;

X_Z1[9] = 3;
Y_Z1[9] = 3;

X_Z1[10] = 2;
Y_Z1[10] = 2;

X_Z1[11] = 1;
Y_Z1[11] = 2;

X_Z1[12] = 0;
Y_Z1[12] = 3;

double *P_Z1 = new double[NumElems_Z1];
P_Z1[0] = 2;
P_Z1[1] = 4;
P_Z1[2] = 5;

INTEGER4 IsDouble = 1;
I = TECDAT112(&NumPts_Z1, X_Z1, &IsDouble);
```

```
I = TECDAT112(&NumPts_Z1, Y_Z1, &IsDouble);
I = TECDAT112(&NumElems_Z1, P_Z1, &IsDouble);
delete X_Z1;
delete Y_Z1;
delete P_Z1;
```

#### Step 4 Specify the face map data for Zone 1

Use the picture in Step 2 to specify the nodes that compose each face. The first two values in the face node array define Face 1, the next two define Face 2, and so on.

```
/* TecPoly Parameters */

/* Create a FaceNodes array, dimensioned by the total number
 * of face nodes in the zone.
 */
INTEGER4 *FaceNodes_Z1 = new INTEGER4[TotalNumFaceNodes_Z1];

/* Face Nodes for Element 1 */
FaceNodes_Z1[0] = 1;
FaceNodes_Z1[1] = 2;

FaceNodes_Z1[2] = 2;
FaceNodes_Z1[3] = 3;

FaceNodes_Z1[4] = 3;
FaceNodes_Z1[5] = 4;

FaceNodes_Z1[6] = 4;
FaceNodes_Z1[7] = 5;

FaceNodes_Z1[8] = 5;
FaceNodes_Z1[9] = 6;
```

```
FaceNodes_Z1[10] = 6;
FaceNodes_Z1[11] = 1;

/* Face Nodes for Element 2 */
FaceNodes_Z1[12] = 3;
FaceNodes_Z1[13] = 7;

FaceNodes_Z1[14] = 7;
FaceNodes_Z1[15] = 8;

FaceNodes_Z1[16] = 8;
FaceNodes_Z1[17] = 9;

FaceNodes_Z1[18] = 9;
FaceNodes_Z1[19] = 10;

FaceNodes_Z1[20] = 10;
FaceNodes_Z1[21] = 4;

/* Face Nodes for Element 3 */
FaceNodes_Z1[22] = 10;
FaceNodes_Z1[23] = 11;

FaceNodes_Z1[24] = 11;
FaceNodes_Z1[25] = 12;

FaceNodes_Z1[26] = 12;
FaceNodes_Z1[27] = 13;

FaceNodes_Z1[28] = 13;
FaceNodes_Z1[29] = 5;
```

## Step 5 Specify the neighboring elements for Zone 1

Now that we have defined the nodes that compose each face, we must specify the element on either side of each face. The neighboring elements can be determined using the right-hand rule. For each face, place your right-hand along the face with your fingers pointing the direction of incrementing node numbers (i.e. from Node 1 to Node 2). The right side of your hand will indicate the right element, and the left side of your hand will indicate the left element. Refer to [Section 3- 8.3 “FaceRightElems and FaceLeftElems”](#) for details.

The number zero is used to indicate that there isn't an element on that side of the face. A negative number is used when the neighboring element is in another zone. The value of the negative number points to the position in the FaceBoundaryConnectionElems and FaceBoundaryConnectionZones arrays that defines the element and zone numbers of the neighboring element. Refer to Step 6 for details.

Because of the way we numbered the nodes and faces, the right element for every face is the element itself. The left element will either be: another element in the zone, “no neighboring element”, or an element in Zone 2. The term “no neighboring element” is used to describe a face that is on the edge of the entire data set (not just the zone).

```
INTEGER4 *FaceLeftElems_Z1 = new INTEGER4 [NumFaces_Z1];
INTEGER4 *FaceRightElems_Z1 = new INTEGER4 [NumFaces_Z1];

/* Left Face Elems for Element 1 */
FaceLeftElems_Z1[0] = 0;
FaceLeftElems_Z1[1] = 0;
FaceLeftElems_Z1[2] = 2;
FaceLeftElems_Z1[3] = 3;
FaceLeftElems_Z1[4] = 0;

/* Left Face Elems for Element 2 */
FaceLeftElems_Z1[5] = 0;
FaceLeftElems_Z1[6] = 0;
FaceLeftElems_Z1[7] = 0;
FaceLeftElems_Z1[8] = -1;
FaceLeftElems_Z1[9] = -2;
FaceLeftElems_Z1[10] = 2;

/* Left Face Elems for Element 3 */
```

```

FaceLeftElems_Z1[11] = -3;
FaceLeftElems_Z1[12] = 0;
FaceLeftElems_Z1[13] = 0;
FaceLeftElems_Z1[14] = 0;

/* Set Right Face Elems.  Because of the way we numbered the
 * nodes and faces, the right element for every face is the
 * element itself.
 */
for(INTEGER4 ii=0;ii<6;ii++)
    FaceRightElems_Z1[ii] = 1;

for(INTEGER4 ii=6;ii<10;ii++)
    FaceRightElems_Z1[ii] = 2;

for(INTEGER4 ii=10;ii<=14;ii++)
    FaceRightElems_Z1[ii] = 3;

```

### Step 6 Specify the boundary connections for Zone 1

The final step for creating Zone 1 is to define the boundary connections and call TECPOLY.

```

/* The FaceBndryConnectionCounts array is used to define the
 * number of boundary connections for each face that has a
 * boundary connection. For example, if a zone has three
 * boundary connections in total (NumConnectedBoundaryFaces),
 * two of those boundary connections are in one face, and the
 * remaining boundary connection is in a second face, the
 * FaceBndryConnectionCounts array would be: [2 1].
 *
 * In this example, the total number of connected boundary
 * faces (specified via TECZNE) is equal to three. Each
 * boundary face is connected to only one other element,

```

```
* so the FaceBoundaryConnectionCounts array is (1, 1, 1).
*/
INTEGER4 FaceBndryConnectionCounts_Z1[3] = {1,1,1};

/* The value(s) in the FaceBndryConnectionElems and
 * FaceBndryConnectionZones arrays specifies the element number
 * and zone number, respectively, that a given boundary
 * connection is connected to. In this case, the first
 * boundary connection face is connected to Element 1 in Zone 2
 * and the remaining connection is to Element 2 in Zone 2.
 */
INTEGER4 FaceBndryConnectionElems_Z1[3] = {1,2,2};
INTEGER4 FaceBndryConnectionZones_Z1[3] = {2,2,2};

I = TECPOLY112(NULL, /* Not used for polygon zones */
               FaceNodes_Z1,
               FaceLeftElems_Z1,
               FaceRightElems_Z1,
               FaceBndryConnectionCounts_Z1,
               FaceBndryConnectionElems_Z1,
               FaceBndryConnectionZones_Z1);

delete FaceNodes_Z1;
delete FaceLeftElems_Z1;
delete FaceRightElems_Z1;
```

## Step 7 Create Zone 2

Now that Zone 1 is complete, we are ready to begin creating Zone 2 by calling TECZNE. For simplicity, we are reusing many of the variables that were defined for Zone 1.

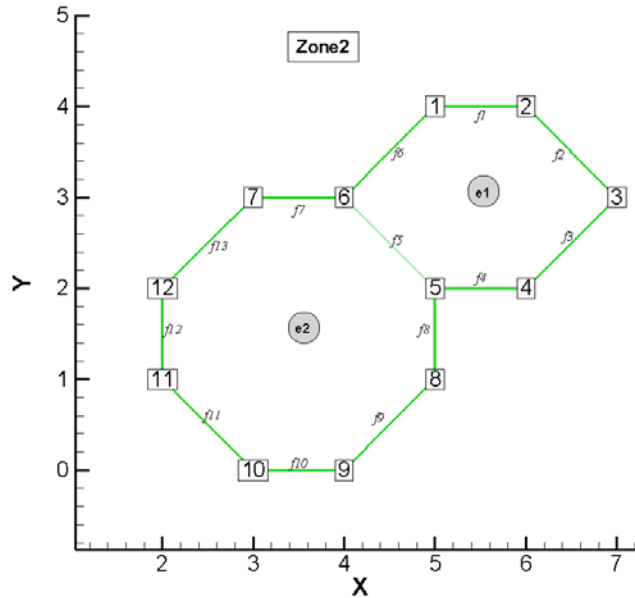

```

INTEGER4 NumPts_Z2           = 12; /* number of unique
                                * nodes in the zone
                                */

INTEGER4 NumElems_Z2        = 2;

INTEGER4 NumFaces_Z2        = 13; /* number of unique
                                * faces in the zone
                                */

INTEGER4 NumFaceConnections_Z2 = 0;
/* In polygonal zones, each face has exactly two nodes */
INTEGER4 TotalNumFaceNodes_Z2 = NumFaces_Z2 * 2;

/* A boundary face is a face that is neighbored by an element or
 * elements from another zone or zone(s). In Zone 2, Face 6,

```

```
* Face 7 and Face 13 have a neighbor in Zone 1. Therefore, the
* total number of boundary faces is i3i.
*/
INTEGER4 TotalNumBndryFaces_Z2 = 3;

/* Each boundary face has one or more boundary connections. In
* this example, each boundary face is connected to one other
* element (i.e. the number of boundary faces and the number of
* boundary connections is one-to-one).
*/
INTEGER4 TotalNumBndryConns_Z2 = 3;

I = TECZNE112("Zone 2: 1 Hexagon and 1 Octagon",
             &ZoneType,
             &NumPts_Z2,
             &NumElems_Z2,
             &NumFaces_Z2,
             &ICellMax,
             &JCellMax,
             &KCellMax,
             &SolutionTime,
             &StrandID,
             &ParentZone,
             &IsBlock,
             &NumFaceConnections_Z2,
             &FaceNeighborMode,
             &TotalNumFaceNodes_Z2,
             &TotalNumBndryFaces_Z2,
             &TotalNumBndryConns_Z2,
             NULL,
             ValueLocation,
```

```

NULL,
&SharConn);

```

## Step 8 Specify the variable values for Zone 2

The variable values are written to the data file via the TECDAT function. For each variable you must provide either a total number of values equivalent to NumPts (if the variables are nodal) or equivalent to NumElements (if the variables are cell-centered). The variable location is specified by the VarLocation parameter in TECZNE. In this example, X and Y are nodal variables and P is cell-centered.

The order in which the variable values must be provided is established by the numbering scheme specified at the beginning of the example. The first value for each nodal variable (X and Y) corresponds to Node 1, the second value corresponds to Node 2 and so forth. The first value for the cell-centered value is for Element 1, the second value is for the second element or cell and so forth.

In order for the example to be easily followed, the grid coordinates are explicitly defined. When working with larger data sets, you will likely wish to use equations to define your coordinates. Refer to the picture in Step 7 for the X and Y coordinate values for Zone 2.

```

double *X_Z2 = new double[NumPts_Z2];
double *Y_Z2 = new double[NumPts_Z2];

X_Z2[0]      = 5;
Y_Z2[0]      = 4;

X_Z2[1]      = 6;
Y_Z2[1]      = 4;

X_Z2[2]      = 7;
Y_Z2[2]      = 3;

X_Z2[3]      = 6;
Y_Z2[3]      = 2;

X_Z2[4]      = 5;
Y_Z2[4]      = 2;

X_Z2[5]      = 4;

```

```
Y_Z2[5]      = 3;

X_Z2[6]      = 3;
Y_Z2[6]      = 3;

X_Z2[7]      = 5;
Y_Z2[7]      = 1;

X_Z2[8]      = 4;
Y_Z2[8]      = 0;

X_Z2[9]      = 3;
Y_Z2[9]      = 0;

X_Z2[10]     = 2;
Y_Z2[10]     = 1;

X_Z2[11]     = 2;
Y_Z2[11]     = 2;

/* In the call to TecZne, P was set to a cell centered variable.
 * As such, only two values need to be defined.
 */
double *P_Z2 = new double[NumPts_Z2];

P_Z2[0] = 8;
P_Z2[1] = 6;

I = TECDAT112(&NumPts_Z2, X_Z2, &IsDouble);
I = TECDAT112(&NumPts_Z2, Y_Z2, &IsDouble);
I = TECDAT112(&NumElems_Z2, P_Z2, &IsDouble);
```

```
delete X_Z2;  
delete Y_Z2;  
delete P_Z2;
```

### Step 9 Specify the face map for Zone 2

Use the picture in Step 7 to specify which nodes compose which face. The first two values in the face node array define Face 1, the next two define Face 2, and so on.

```
INTEGER4 *FaceNodes_Z2;  
FaceNodes_Z2 = new INTEGER4[TotalNumFaceNodes_Z2];  
  
/* Face Nodes for Element 1 */  
FaceNodes_Z2[0] = 1;  
FaceNodes_Z2[1] = 2;  
  
FaceNodes_Z2[2] = 2;  
FaceNodes_Z2[3] = 3;  
  
FaceNodes_Z2[4] = 3;  
FaceNodes_Z2[5] = 4;  
  
FaceNodes_Z2[6] = 4;  
FaceNodes_Z2[7] = 5;  
  
FaceNodes_Z2[8] = 5;  
FaceNodes_Z2[9] = 6;  
  
FaceNodes_Z2[10] = 6;  
FaceNodes_Z2[11] = 1;  
  
/* Face Nodes for Element 2 */
```

```
FaceNodes_Z2[12] = 7;
FaceNodes_Z2[13] = 6;

FaceNodes_Z2[14] = 5;
FaceNodes_Z2[15] = 8;

FaceNodes_Z2[16] = 8;
FaceNodes_Z2[17] = 9;

FaceNodes_Z2[18] = 9;
FaceNodes_Z2[19] = 10;

FaceNodes_Z2[20] = 10;
FaceNodes_Z2[21] = 11;

FaceNodes_Z2[22] = 11;
FaceNodes_Z2[23] = 12;

FaceNodes_Z2[24] = 12;
FaceNodes_Z2[25] = 7;
```

## Step 10 Specify the neighboring elements for Zone 2

Now that we have defined the nodes that compose each face, we must specify the element on either side of each face. The neighboring elements can be determined using the right-hand rule. For each face, place your right-hand along the face with your fingers pointing the direction of incrementing node numbers (i.e. from Node 1 to Node 2). The right side of your hand will indicate the right element, and the left side of your hand will indicate the left element. Refer to [Section 3- 8.3 “FaceRightElems and FaceLeftElems”](#) for details.

The number zero is used to indicate that there isn't an element on that side of the face. A negative number is used when the neighboring element is in another zone. The value of the negative number points to the position in the `FaceBoundaryConnectionElems` and `FaceBoundaryConnectionZones` arrays that defines the element and zone numbers of the neighboring element. Refer to Step 11 for details.

Because of the way we numbered the nodes and faces, the right element for every face is the element itself. The left element will either be: another element in the zone, “no neighboring ele-

ment”, or an element in Zone 2. The term “no neighboring element” is used to describe a face that is on the edge of the entire data set (not just the zone).

```
INTEGER4 *FaceNodes_Z2;
FaceNodes_Z2 = new INTEGER4[TotalNumFaceNodes_Z2];

/* Face Nodes for Element 1 */
FaceNodes_Z2[0] = 1;
FaceNodes_Z2[1] = 2;

FaceNodes_Z2[2] = 2;
FaceNodes_Z2[3] = 3;

FaceNodes_Z2[4] = 3;
FaceNodes_Z2[5] = 4;

FaceNodes_Z2[6] = 4;
FaceNodes_Z2[7] = 5;

FaceNodes_Z2[8] = 5;
FaceNodes_Z2[9] = 6;

FaceNodes_Z2[10] = 6;
FaceNodes_Z2[11] = 1;

/* Face Nodes for Element 2 */
FaceNodes_Z2[12] = 7;
FaceNodes_Z2[13] = 6;

FaceNodes_Z2[14] = 5;
FaceNodes_Z2[15] = 8;
```

```
FaceNodes_Z2[16] = 8;  
FaceNodes_Z2[17] = 9;  
  
FaceNodes_Z2[18] = 9;  
FaceNodes_Z2[19] = 10;  
  
FaceNodes_Z2[20] = 10;  
FaceNodes_Z2[21] = 11;  
  
FaceNodes_Z2[22] = 11;  
FaceNodes_Z2[23] = 12;  
  
FaceNodes_Z2[24] = 12;  
FaceNodes_Z2[25] = 7;
```

### Step 11 Specify the Boundary Connections for Zone 2

The final step for creating Zone 2 is to define the boundary connections and call TECPOLY

```
/* The FaceBndryConnectionCounts array is used to define the  
* number of boundary connections for each face that has a  
* boundary connection. In this example, the total number of  
* connected boundary faces (specified via TECZNE) is equal to  
* three. Each boundary face is connected to only one other  
* element, so the FaceBoundaryConnectionCounts array is  
* (1, 1, 1).  
*/  
INTEGER4 FaceBndryConnectionCounts_Z2[3] = {1,1,1};  
  
/* The value(s) in the FaceBndryConnectionElems and  
* FaceBndryConnectionZones arrays specifies that element  
* number and zone number, respectively, that a given boundary  
* connection is connected to. In this case, the first boundary  
* connection face is connected to Element 2 in Zone 1 and the
```

```

    * remaining connections are Element 3 in Zone 1.
    */
    INTEGER4 FaceBndryConnectionElems_Z2[3] = {2,3,3};
    INTEGER4 FaceBndryConnectionZones_Z2[3] = {1,1,1};

    I = TECPOLY112(NULL,
                  FaceNodes_Z2,
                  FaceLeftElems_Z2,
                  FaceRightElems_Z2,
                  FaceBndryConnectionCounts_Z2,
                  FaceBndryConnectionElems_Z2,
                  FaceBndryConnectionZones_Z2);

    delete FaceNodes_Z2;
    delete FaceLeftElems_Z2;
    delete FaceRightElems_Z2;

```

### Step 12 Close the file using TECEND

Call TECEND to close the file.

```
I = TECEND112();
```

### 3- 9.5 Polyhedral Example

The following example (written in C) illustrates how to create a single polyhedral cell using the TecIO library.

```

#include "TECIO.h"
#include "MASTER.h" /* for defintion of NULL */

int main()
{
    /* Call TECINI112 */
    INTEGER4 FileType = 0; /* 0 for full file */
    INTEGER4 Debug = 0;

```

```
INTEGER4 VisDouble = 1;
INTEGER4 I          = 0; /* use to check return codes */

I = TECINI112("Pyramid", /* Data Set Title */
             "X Y Z",    /* Variable List */
             "pyramid.plt", /* File Name */
             ".",        /* Scratch Directory */
             &(FileType),
             &(Debug),
             &(VisDouble));

/* Call TECZNE112 */
INTEGER4 ZoneType = 7; /* 7 for FEPolyhedron */
INTEGER4 NumNodes = 5; /* number of unique nodes */
INTEGER4 NumElems = 1; /* number of elements */
INTEGER4 NumFaces = 5; /* number of unique faces */

INTEGER4 ICellMax = 0; /* Not Used, set to zero */
INTEGER4 JCellMax = 0; /* Not Used, set to zero */
INTEGER4 KCellMax = 0; /* Not Used, set to zero */

double SolTime = 12.65; /* solution time */
INTEGER4 StrandID = 0; /* static zone */
INTEGER4 ParentZone = 0; /* no parent zone */

INTEGER4 IsBlock = 1; /* block format */

INTEGER4 NFConns = 0; /* not used for FEPolyhedron
                      * zones
                      */
INTEGER4 FNMode = 0; /* not used for FEPolyhedron
```

```

                                * zones
                                */

INTEGER4 *PassiveVarArray = NULL;
INTEGER4 *ValueLocArray  = NULL;
INTEGER4 *VarShareArray  = NULL;

INTEGER4  ShrConn        = 0;

/* The number of face nodes in the zone.  This example creates
 * a zone with a single pyramidal cell.  This cell has four
 * triangular faces and one rectangular face, yielding a total
 * of 16 face nodes.
 */
INTEGER4  NumFaceNodes   = 16;
INTEGER4  NumBConns      = 0;  /* No Boundary Connections */
INTEGER4  NumBItems      = 0;  /* No Boundary Items */

I = TECZNE112("Polyhedral Zone (Octahedron)",
              &ZoneType,
              &NumNodes,
              &NumElems,
              &NumFaces,
              &ICellMax,
              &JCellMax,
              &KCellMax,
              &SolTime,
              &StrandID,
              &ParentZone,
              &IsBlock,
              &NFConns,
              &FNMode,
```

```
        &NumFaceNodes ,
        &NumBConns ,
        &NumBItems ,
        PassiveVarArray ,
        ValueLocArray ,
        VarShareArray ,
        &ShrConn) ;

/* Initialize arrays of nodal data */
double *X = new double[NumNodes] ;
double *Y = new double[NumNodes] ;
double *Z = new double[NumNodes] ;

X[0] = 0 ;
Y[0] = 0 ;
Z[0] = 0 ;

X[1] = 1 ;
Y[1] = 1 ;
Z[1] = 2 ;

X[2] = 2 ;
Y[2] = 0 ;
Z[2] = 0 ;

X[3] = 2 ;
Y[3] = 2 ;
Z[3] = 0 ;

X[4] = 0 ;
Y[4] = 2 ;
Z[4] = 0 ;
```

```
/* Write the data (using TECDAT112) */
INTEGER4 DIsDouble = 1; /* One for double precision */
I = TECDAT112(&NumNodes, X, &DIsDouble);
I = TECDAT112(&NumNodes, Y, &DIsDouble);
I = TECDAT112(&NumNodes, Z, &DIsDouble);

delete X;
delete Y;
delete Z;

/* Define the Face Nodes.

* The FaceNodes array is used to indicate which nodes define
* which face. As mentioned earlier, the number of the nodes is
* implicitly defined by the order in which the nodal data is
* provided. The first value of each nodal variable describes
* node 1, the second value describes node 2, and so on.
*
* The face numbering is implicitly defined. Because there are
* two nodes in each face, the first two nodes provided define
* face 1, the next two define face 2 and so on. If there was
* a variable number of nodes used to define the faces, the
* array would be more complicated.
*/

INTEGER4 *FaceNodeCounts = new INTEGER4[NumFaces];
/* The first four faces are triangular, i.e. have three nodes.
* The fifth face is rectangular, i.e. has four nodes. */
FaceNodeCounts[0] = 3;
FaceNodeCounts[1] = 3;
FaceNodeCounts[2] = 3;
```

```
FaceNodeCounts[3] = 3;
FaceNodeCounts[4] = 4;

INTEGER4 *FaceNodes = new INTEGER4[NumFaceNodes];
/* Face Nodes for Face 1 */
FaceNodes[0] = 1;
FaceNodes[1] = 2;
FaceNodes[2] = 3;

/* Face Nodes for Face 2 */
FaceNodes[3] = 3;
FaceNodes[4] = 2;
FaceNodes[5] = 4;

/* Face Nodes for Face 3 */
FaceNodes[6] = 5;
FaceNodes[7] = 2;
FaceNodes[8] = 4;

/* Face Nodes for Face 4 */
FaceNodes[9] = 1;
FaceNodes[10] = 2;
FaceNodes[11] = 5;

/* Face Nodes for Face 5 */
FaceNodes[12] = 1;
FaceNodes[13] = 5;
FaceNodes[14] = 4;
FaceNodes[15] = 3;

/* Define the right and left elements of each face.
*
```

```
* The last step for writing out the polyhedral data is to
* define the right and left neighboring elements for each
* face. The neighboring elements can be determined using the
* right-hand rule. For each face, place your right-hand along
* the face which your fingers pointing the direction of
* incrementing node numbers (i.e. from node 1 to node 2).
* Your right thumb will point towards the right element; the
* element on the other side of your hand is the left element.
*
* The number zero is used to indicate that there isn't an
* element on that side of the face.
*
* Because of the way we numbered the nodes and faces, the
* right element for every face is the element itself
* (element 1) and the left element is "no-neighboring element"
* (element 0).
*/

INTEGER4 *FaceLeftElems = new INTEGER4[NumFaces];
FaceLeftElems[0] = 1;
FaceLeftElems[1] = 1;
FaceLeftElems[2] = 0;
FaceLeftElems[3] = 0;
FaceLeftElems[4] = 0;

INTEGER4 *FaceRightElems = new INTEGER4[NumFaces];
FaceRightElems[0] = 0;
FaceRightElems[1] = 0;
FaceRightElems[2] = 1;
FaceRightElems[3] = 1;
FaceRightElems[4] = 1;
```

```
/* Write the face map (created above) using TECPOLY112. */
I = TECPOLY112(FaceNodeCounts, /* The face node counts array */
              FaceNodes,      /* The face nodes array */
              FaceLeftElems,  /* The left elements array */
              FaceRightElems, /* The right elements array */
              NULL,           /* No boundary connection counts */
              NULL,           /* No boundary connection elements */
              NULL);         /* No boundary connection zones */

delete FaceNodeCounts;
delete FaceNodes;
delete FaceLeftElems;
delete FaceRightElems;

I = TECEND112();
return 0;
}
```

### 3- 9.6 IJ-ordered zone

The following example illustrates how to create a simple IJ-ordered zone. [TECZNE112](#) is called first to initialize the zone.

```
#include "TECIO.h"
#include "MASTER.h" /* for definition of NULL */

int main ()
{
    INTEGER4 Debug      = 1;
    INTEGER4 VIsDouble  = 0;
    INTEGER4 FileType   = 0;
    INTEGER4 I          = 0; /* Used to track return codes */
}
```

```
/*
 * Open the file and write the tecplot datafile
 * header information
 */
I = TECINI112("IJ Ordered Zones", /* Name of the entire
 * dataset.
 */
            "X Y P", /* Defines the variables for the data
 * file. Each zone must contain each of
 * the variables listed here. The order
 * of the variables in the list is used
 * to define the variable number (e.g.
 * X is Var 1).
 */
            "ij_ordered.plt",
            ".", /* Scratch Directory */
            &FileType,
            &Debug,
            &VIsDouble);

float X1[4];
float Y1[4];
float P1[4];
float X2[4];
float Y2[4];
float P2[4];

INTEGER4 ICellMax           = 0;
INTEGER4 JCellMax           = 0;
INTEGER4 KCellMax           = 0;
INTEGER4 DIsDouble         = 0;
double   SolTime            = 360.0;
```

```
INTEGER4 StrandID           = 0;      /* StaticZone */
INTEGER4 ParentZn           = 0;
INTEGER4 IsBlock            = 1;      /* Block */
INTEGER4 NFConns            = 0;
INTEGER4 FNMode             = 0;
INTEGER4 TotalNumFaceNodes  = 1;
INTEGER4 TotalNumBndryFaces = 1;
INTEGER4 TotalNumBndryConnections = 1;
INTEGER4 ShrConn            = 0;

/*Ordered Zone Parameters*/
INTEGER4 IMax = 2;
INTEGER4 JMax = 2;
INTEGER4 KMax = 1;

X1[0] = .125;
Y1[0] = .5;
P1[0] = 5;

X1[1] = .625;
Y1[1] = .5;
P1[1] = 7.5;

X1[2] = .125;
Y1[2] = .875;
P1[2] = 10;

X1[3] = .625;
Y1[3] = .875;
P1[3] = 7.5;

X2[0] = .375;
```

```
Y2[0] = .125;
P2[0] = 5;

X2[1] = .875;
Y2[1] = .125;
P2[1] = 7.5;

X2[2] = .375;
Y2[2] = .5;
P2[2] = 10;

X2[3] = .875;
Y2[3] = .5;
P2[3] = 7.5;

/* Ordered Zone */
INTEGER4 ZoneType = 0;
I = TECZNE112("Ordered Zone",
              &ZoneType,
              &IMax,
              &JMax,
              &KMax,
              &ICellMax,
              &JCellMax,
              &KCellMax,
              &SolTime,
              &StrandID,
              &ParentZn,
              &IsBlock,
              &NFConns,
              &FNMode,
              &TotalNumFaceNodes,
```

```
        &TotalNumBndryFaces ,
        &TotalNumBndryConnections ,
        NULL ,
        NULL ,
        NULL ,
        &ShrConn) ;

INTEGER4 III = IMax * JMax * KMax ;
I   = TECDAT112 (&III, X1, &DIsDouble) ;
I   = TECDAT112 (&III, Y1, &DIsDouble) ;
I   = TECDAT112 (&III, P1, &DIsDouble) ;

I = TECZNE112 ("Ordered Zone2" ,
              &ZoneType ,
              &IMax ,
              &JMax ,
              &KMax ,
              &ICellMax ,
              &JCellMax ,
              &KCellMax ,
              &SolTime ,
              &StrandID ,
              &ParentZn ,
              &IsBlock ,
              &NFConns ,
              &FNMode ,
              &TotalNumFaceNodes ,
              &TotalNumBndryFaces ,
              &TotalNumBndryConnections ,
              NULL ,
              NULL ,
              NULL ,
              &ShrConn) ;
```

```

I = TECDAT112 (&III, X2, &DIsDouble);
I = TECDAT112 (&III, Y2, &DIsDouble);
I = TECDAT112 (&III, P2, &DIsDouble);

I = TECEND112 ();
return 0;
}

```

### 3- 9.7 Switching between two files

In this simplified example, information is written to two separate files. First, one file is created and a zone is written to the file. Then, a second file is created and a zone and auxiliary data are written to the file. The second file is closed and the auxiliary data is written to the first file. INTEGER4 DemoTecFil(void)

```

#include "TECIO.h"
#include "MASTER.h" /* for defintion of NULL */
#include <string.h>

int main ()
{
    /*
     * Open the file and write the tecplot datafile
     * header information
     */
    INTEGER4 Debug      = 1;
    INTEGER4 VIsDouble  = 0;
    INTEGER4 FileType   = 0;
    INTEGER4 I          = 0; /* Used to check the return value */

    I = TECINI112("SIMPLE DATASET", /* Name of the entire dataset.*/

                "X1 Y1 P1", /* Defines the variables for the data

```

```

* file. Each zone must contain each of
* the variables listed here. The order
* of the variables in the list is used
* to define the variable number (e.g.
* X1 is Var 1).
*/
"file1.plt",
".", /* Scratch Directory */
&FileType,
&Debug,
&VisDouble);

/* Set the parameters for TecZne */
INTEGER4 ZoneType      = 0; /* sets the zone type to
* ordered
*/
INTEGER4 IMax          = 2; /* Create an IJ-ordered zone,
* by using IMax and JMax
* values that are greater
* than one, and setting KMax
* to one.
*/
INTEGER4 JMax          = 2;
INTEGER4 KMax          = 1;

double   SolTime       = 0;
INTEGER4 StrandID      = 0; /* StaticZone */
INTEGER4 ParentZn      = 0; /* used for surface streams */

INTEGER4 ICellMax      = 0; /* not used */
INTEGER4 JCellMax      = 0; /* not used */
INTEGER4 KCellMax      = 0; /* not used */
```

```
INTEGER4 IsBlock          = 1; /* Block */

INTEGER4 NFConns          = 0; /* this example does not use
                               * face neighbors */

INTEGER4 FNMode           = 0;
INTEGER4 TotalNumFaceNodes = 1;
INTEGER4 TotalNumBndryFaces = 1;
INTEGER4 TotalNumBndryConn = 1;
INTEGER4 ShrConn          = 0;

/* Create an Ordered Zone */
I = TECZNE112("Ordered Zone",
              &ZoneType,
              &IMax,
              &JMax,
              &KMax,
              &ICellMax,
              &JCellMax,
              &KCellMax,
              &SolTime,
              &StrandID,
              &ParentZn,
              &IsBlock,
              &NFConns,
              &FNMode,
              &TotalNumFaceNodes,
              &TotalNumBndryFaces,
              &TotalNumBndryConn,
              NULL,
              NULL,
```

```
        NULL,  
        &ShrConn);  
  
    /* Set the variable values for the ordered zone. */  
    float X1[4];  
    float Y1[4];  
    float P1[4];  
  
    X1[0] = 0.125;  
    Y1[0] = 0.5;  
    P1[0] = 7.5;  
  
    X1[1] = 0.625;  
    Y1[1] = 0.5;  
    P1[1] = 10.0;  
  
    X1[2] = 0.125;  
    Y1[2] = 0.875;  
    P1[2] = 5.0;  
  
    X1[3] = 0.625;  
    Y1[3] = 0.875;  
    P1[3] = 7.5;  
  
    INTEGER4 DIsDouble = 0; /* set DIsDouble to 0, for float  
                             * values.  
                             */  
  
    INTEGER4 III = IMax * JMax * KMax;  
    I = TECDAT112(&III,X1,&DIsDouble);  
    I = TECDAT112(&III,Y1,&DIsDouble);  
    I = TECDAT112(&III,P1,&DIsDouble);
```

```
/* Open a new data file. note: the first file is still open
 * because TecEnd was not called.
 */
I = TECINI112("Auxiliary Data",
             "X1 Y1 P1",
             "file2.plt",
             ".",
             &FileType,
             &Debug,
             &VIsDouble);

/* Switch the active file to the newly created data file
 * (file2.plt) which is the second file opened with TECINI112
 * so we use 2.
 */
INTEGER4 WhichFile = 2;
I = TECFIL112(&WhichFile);

/* Create a second zone, using many of the values from the first
 * zone, and write it to the second data file.
 */

I = TECZNE112("Ordered Zone2",
             &ZoneType,
             &IMax,
             &JMax,
             &KMax,
             &ICellMax,
             &JCellMax,
             &KCellMax,
             &SolTime,
```

```
        &StrandID,  
        &ParentZn,  
        &IsBlock,  
        &NFConns,  
        &FNMode,  
        &TotalNumFaceNodes,  
        &TotalNumBndryFaces,  
        &TotalNumBndryConn,  
        NULL,  
        NULL,  
        NULL,  
        &ShrConn);  
  
/* set the variable values for the second zone */  
float X2[4];  
float Y2[4];  
float P2[4];  
  
X2[0] = 0.375;  
Y2[0] = 0.125;  
P2[0] = 5;  
  
X2[1] = 0.875;  
Y2[1] = 0.125;  
P2[1] = 7.5;  
  
X2[2] = 0.375;  
Y2[2] = 0.5;  
P2[2] = 10;  
  
Y2[3] = 0.5;  
X2[3] = 0.875;  
P2[3] = 7.5;
```

```
III = IMax * JMax * KMax;
I   = TECDAT112 (&III, X2, &DisDouble);
I   = TECDAT112 (&III, Y2, &DisDouble);
I   = TECDAT112 (&III, P2, &DisDouble);

/* Switch to the first file. */
WhichFile = 1;
I = TECFIL112 (&WhichFile);

/* Create an auxiliary data value and write it to the file */
char DeformationValue[128];
strcpy(DeformationValue, "0.98");

I = TECAUXSTR112 ("DeformationValue",
                 DeformationValue);
/* Close the first file */
I = TECEND112 ();

/* The remaining file will become the active file. As such,
 * TecFil does not need to be called again to close the second
 * file.
 */
I = TECEND112 ();

return 0;
}
```

### 3- 9.8 Text Example

The following example creates a data file with a single text box reading "Sample Text".

```
#include "TECIO.h"
#include <string.h>

int main ()
{
    /* Open the file & write the datafile header information */
    INTEGER4 Debug      = 1;
    INTEGER4 VIsDouble = 0;
    INTEGER4 FileType   = 0;
    INTEGER4 I          = 0; /* used to check the return value */

    I = TECINI112("Text",
                 "X Y P",
                 "text.plt",
                 ".",
                 &FileType,
                 &Debug,
                 &VIsDouble);

    /* Specify the X, Y and Z position of the anchor point */
    double   XPos          = 0.0;
    double   YPos          = 1.0;
    double   ZPos          = 0.0; /* N/A for 2D text */

    INTEGER4 PosCoordMode = 0; /* use grid coordinates */

    /* opt not to attach the text to a given zone.  When text is
     * attached to a given zone, it is displayed only when the zone
     * is displayed.
    */
}
```

```
*/
INTEGER4 AttachToZone      = 0;
INTEGER4 Zone              = 2;

/* Specify the font values */
INTEGER4 Font              = 1; /* Helvetica Bold */
INTEGER4 FontHeightUnits  = 2; /* in grid coordinates */
double   FontHeight       = 18;

/* Set the box style parameters */
INTEGER4 BoxType          = 1; /* filled box */
double   BoxMargin        = .5; /* margin between the text
                                * and the text box
                                */
double   BoxLineThickness = .1;
INTEGER4 BoxColor         = 0; /* set the box line color
                                * to black.
                                */
INTEGER4 BoxFillColor     = 1; /* set the box fill color
                                * to red.
                                */

/* set the font properties */
double   Angle            = 30; /* angle of the text */
INTEGER4 Anchor           = 1; /* set the anchor point to
                                * the center of the text
                                * box.
                                */
double   LineSpacing      = 1.5;
INTEGER4 TextColor        = 7; /* set the font color to
                                * white
```

```

                                                                    */
INTEGER4 Scope                = 1;    /* set the text to "local",
                                        * i.e. available in the
                                        * current frame only.
                                        */

INTEGER4 Clipping             = 1;

char    Text[60];
char    MFC[24];
strcpy(Text,"Sample Text");
strcpy(MFC,"My Macro");

I = TECTXT112(&XPos,
              &YPos,
              &ZPos,
              &PosCoordMode,
              &AttachToZone,
              &Zone,
              &Font,
              &FontHeightUnits,
              &FontHeight,
              &BoxType,
              &BoxMargin,
              &BoxLineThickness,
              &BoxColor,
              &BoxFillColor,
              &Angle,
              &Anchor,
              &LineSpacing,
              &TextColor,
```

```
        &Scope,  
        &Clipping,  
        Text,  
        MFC);  
  
    I = TECEND112();  
  
    return 0;  
}
```

### 3- 9.9 Geometry Example

The following example creates a data file with a single square geometry and no zones.







Files exported into Tecplot's data format may be either ASCII or binary. However, we strongly recommend using Tecplot's binary file format (\*.plt). The ASCII file format is provided to illustrate how data is structured in Tecplot. ASCII data format is useful only for very small data files. Reading an ASCII data file into Tecplot 360 can be much slower than reading a binary data file, as binary data files are structured for more efficient data access, and Tecplot 360 must convert from ASCII to binary prior to loading the data. Refer to [Chapter 3 "Binary Data"](#) for information on creating files in Tecplot's binary format.

## 4 - 1 Preplot

Tecplot 360 or Preplot converts ASCII data files to binary. See [Section 4 - 15 "Tecplot-Format Loader"](#) in the [User's Manual](#) for converting with Tecplot 360, or [Section 4 - 6 "ASCII Data File Conversion to Binary"](#) for converting with Preplot. A description of the binary format is included in [Appendix A "Binary Data File Format"](#). Finally, if your data is generated in FORTRAN or C, you may be able to generate binary data files directly using the utilities described in [Chapter 3 "Binary Data"](#).

Alternatively, you may write your own Tecplot data loader using Tecplot 360's Add-on Developer's Kit (ADK). Refer to [Chapter 27 "Creating a Data Loader"](#) in the [ADK User's Manual](#) for details.

## 4 - 2 Syntax Rules & Limits

An ASCII data file begins with a file header defining a title for the data file and/or the names of the variables. The header is followed by zone records containing the plot data. Zone records may contain ordered or finite element data. You may also include text, geometry, and custom-label records that create text, geometries, and/or custom labels on plots. The records in the file may be in any order.

ASCII data files have the following limits:

- **Number of Records** - Each data file may have ten custom label records, and any number of text and geometry records.
- **Maximum Characters per Line** - The maximum length of a line in a data file is 32,000 characters.

There are additional limits specific to some of the record types and parameters. These limits are discussed in the section for the associated record type or parameter.

When writing an ASCII data file, please keep the following syntax rules in mind:

- **Character Strings** - Double quotes must be used to enclose character strings with embedded blank spaces or other special characters.
- **Multiple Lines** - Any line may be continued onto one or more following lines (except for text enclosed in double quotes ["]).
- **Escape Characters** - A backslash (\) may be used to remove the significance of (or escape) the next character (that is, \" produces a single double-quote).
- **Comments** - Any line beginning with an # is treated as a comment and ignored.

The following simple example of a Tecplot 360 ASCII data file has one small zone and a single line of text:

```
TITLE="Simple Data File"
VARIABLES="X" "Y"
ZONE I=4 DATAPACKING=POINT
1 1
2 1
2 2
1 2
TEXT X=10 Y=90 T="Simple Text"
```

### 4 - 3 ASCII File Structure

An ASCII data file begins with an file header defining a title for the data file and or the names of the variables. The header is followed by optional zone records containing the plot data. Zone records may contain ordered or finite element data. Refer to [Chapter 3 “Data Structure”](#) in the [User’s Manual](#) for a complete description of ordered and finite element data. You may also include text, geometry, and custom-label records, in any order.

The first line in a zone, text, geometry, custom label, data set auxiliary data record or variable auxiliary record begins with the keyword **ZONE**, **TEXT**, **GEOMETRY**, **CUSTOMLABELS**, **DATASET-AUXDATA**, or **VARAUXDATA**.

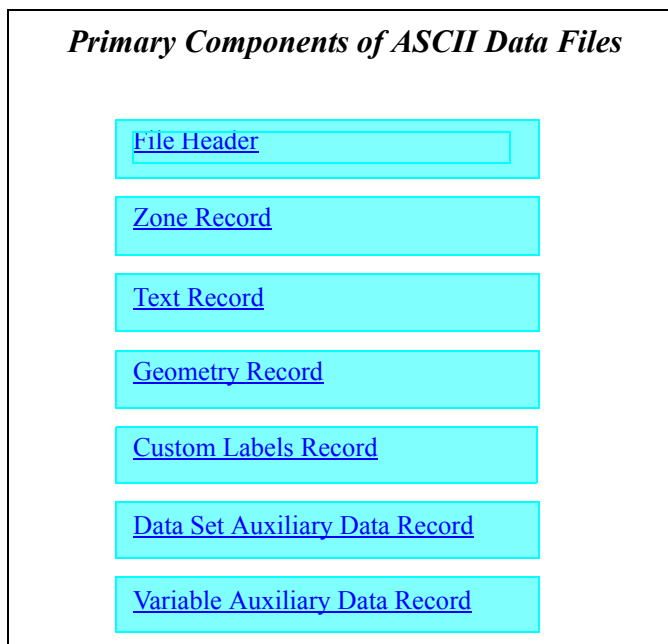

### 4- 3.1 File Header

The File Header is an optional component of an ASCII data file. It may contain a [TITLE](#), [FILE-TYPE](#) and/or a [VARIABLES](#) list. If the file header occurs in a place other than at the top of the data file, a warning is printed and the header is ignored. This allows you to concatenate two or more ASCII data files before using Tecplot 360 (provided each data file has the same number of variables per data point).

## File Header Components

Token	Syntax	Notes
<b>TITLE</b>	= "<string>"	The title will be displayed in the headers of Tecplot 360 frames.
<b>FILETYPE</b>	= <i>FULL</i> , <i>GRID</i> or <i>SOLUTION</i>	Specifies the data file type. A full data file contains both grid and solution data. If omitted, the FILETYPE will be treated as "FULL".
<b>VARIABLES</b>	= "VARIABLE1", "VARIABLE2", "VARIABLE3", ..., "VARIABLEN"	You may also assign a name to each of the variables by including a line that begins with VARIABLES=, followed by each variable's name enclosed in double quotes. Tecplot 360 calculates the number of variables (N) from the list of variable names. If you do not specify the variable names (and your first zone has POINT data packing), Tecplot 360 sets the number of variables equal to the number of numeric values in the first line of zone data for the first zone, and names the variables V1, V2, V3, and so forth. Initially, Tecplot 360 uses the first two variables in data files as the X- and Y-coordinates, and the third variable for the Z-coordinate of 3D plots. However, you may order the variables in the data file any way you want, since you can interactively reassign the variables to the X-, Y-, and/or Z-axis via the <b>Select Variables</b> dialog (accessed via <b>Plot&gt;Assign XYZ</b> ).

### Example Grid File

The following example displays a very simple 2D grid file.

```
#"Grid" files look like standard Tecplot data files with no solution
variables.
TITLE = "Example Grid File"
FILETYPE = GRID
VARIABLES = "X" "Y"
ZONE
I = 3, J = 3, K = 1
ZONETYPE = Ordered, DATAPACKING = BLOCK
0.0   0.5   1.0   0.0   0.5   1.0   0.0   0.5   1.0
0.0   0.0   0.0   0.5   0.5   0.5   1.0   1.0   1.0
```

### Example Solution File

The following example displays a very simple solution file (to be used with the [Example Grid File](#)).

```
TITLE = "Example Solution File"
FILETYPE = SOLUTION
VARIABLES = "Pressure"
ZONE
I = 3, J = 3, K = 1
ZONETYPE = Ordered, DATAPACKING = BLOCK
2.0   2.0   2.0   0.0   0.0   0.0   2.0   2.0   2.0
```

## 4-3.2 Zone Record

A zone record consists of a control line that begins with the keyword **ZONE**, followed by the zone header, followed by a set of numerical data called the zone data. The contents of the zone footer

depend upon the type of zone. Refer to the following table for an overview of the contents of a zone record.

<b>Component</b>	<b>Notes</b>
<b>ZONE</b>	The keyword “ZONE” is required at the start of every zone record
<a href="#">Zone Header</a>	The Zone Header is used to specify the type of data in the zone, the structure of the data, the names of the variables in the zone, and more. Refer to <a href="#">“Zone Header”</a> on page 156 for details.
<a href="#">Data</a>	The data section follows the zone header. The arrangement of the data is dependent upon the values of <a href="#">DATAPACKING</a> and <a href="#">VARLOCATION</a> (specified in the <a href="#">Zone Header</a> ). Refer to <a href="#">“Data”</a> on page 160 for details.
<a href="#">Zone Footer</a>	<p>The contents required for the Zone Footer depend upon the <a href="#">ZONETYPE</a> (specified in the <a href="#">Zone Header</a>).</p> <p>For ordered zones, the Zone Footer contains the <a href="#">Face Neighbor Connections List</a> information (if any).</p> <p>For cell-based finite element zones (FETRIANGLE, FEQUADILATERAL, FETETRAHEDRAL and FEBRICK), the Zone Footer contains <a href="#">Connectivity</a> information, followed by <a href="#">Face Neighbor Connections List</a>.</p> <p>For face-based finite element zones (FEPOLYHEDRAL, FEPOLYGON), the Zone Footer contains <a href="#">Facemap Data</a>, followed by <a href="#">Boundary Map Data</a>.</p> <p>Refer to <a href="#">“Zone Footer”</a> on page 162 for additional information.</p>

## Zone Header

Keyword	Syntax	Required (Y/N)	Default	Notes
<b>ZONE</b>		Y		Keyword required to start a zone record
<b>T</b>	= <string>	N		Zone Title. This may be any text string up to 128 characters in length. If you supply a longer text string, it is automatically truncated to the first 128 characters. The titles of zones appear in the <b>Zone Style</b> and other dialogs, and, optionally, in the XY- plot legend.
<b>ZONETYPE</b>	= <zonetype>	N	ORDERED	<p>The zone data are of the type specified by the <b>ZONETYPE</b> parameter in the control line. There are two basic types of zones: ordered and finite element. <b>ORDERED</b> is presumed if the <b>ZONETYPE</b> parameter is omitted. See <a href="#">Section 4 - 4 "Ordered Data"</a> for more information on ordered zones, and <a href="#">Section 4 - 5 "Finite Element Data"</a> for details on finite element data.</p> <p>When specifying your ZoneType, please note that some features in Tecplot 360 are limited by zone type. For example, iso-surfaces and slices are available for 3D zones types only (FETETRAHEDRON, FEBRICK, FEPOLYHEDRON and ORDERED - with K greater than 1).</p> <p>However, the plot type that you specify (in Tecplot 360 once you have loaded your data) is not limited by your zone type. You may have a 3D zone displayed in a 2D Cartesian plot (and visa versa).</p>
<b>I</b>	= <integer>	Y		Specify the maximum number of points in the I- J- or K-direction. Use only when <a href="#">ZONETYPE</a> is ORDERED.
<b>J</b>	= <integer>	Y		
<b>K</b>	= <integer>	Y		
<b>NODES</b>	= <integer>	Y		Use for finite element zone types only (i.e. not ordered zones). Specify the total number of NODES, ELEMENTS and FACES in the data file. Refer to <a href="#">Section 4 - 5 "Finite Element Data"</a> for additional information.
<b>ELEMENTS</b>	= <integer>	Y		
<b>FACES</b>	= <integer>	Y		
<b>TOTALNUMFACENODES</b>	= <integer>	Y (for polyhedral zones)		For face-based finite element zones only. Total number of nodes in the <a href="#">Facemap Data</a> section for all faces. This is optional for polygons as TotalNumFaceNodes = 2*NumFaces.
<b>NUMCONNECTEDBOUNDARYFACES</b>	= <integer>	Y		For face-based finite element zones only. Total number of boundary faces listed in the <a href="#">Facemap Data</a> section. Set to zero if boundary faces aren't used.

Keyword	Syntax	Required (Y/N)	Default	Notes
<b>TOTALNUMBERBOUNDARYCONNECTIONS</b>	= <integer>	Y		For face-based finite element zones only. Total number of entries for boundary items listed in the <a href="#">Facemap Data</a> section. Set to zero if boundary faces aren't used.
<b>FACENEIGHBORMODE</b>	= [LOCALONE TOONE,  LOCALONET OMANY,  GLOBALON ETOONE,  GLOBALON ETOMANY]	N	LOCALONE NETOONE	For ordered or cell-based finite element zones only. Used to indicate whether the neighboring faces are within the current zone or in another zone (i.e. local or global), as well as whether the connections are one-to-one or one-to-many. When this token is used, both the <a href="#">FACENEIGHBORCONNECTIONS</a> token and the FaceNeighbor Connections List are required. Refer to <a href="#">Section "Face Neighbor Connections List"</a> on page 163 for details.
<b>FACENEIGHBORCONNECTIONS</b>	= <integer>	Y, if <a href="#">FACENEIGHBORMODE</a> is in use.		For ordered or cell-based finite element zones only. Used to indicate the total number of connections for all elements in the zone. For example, if you have two cells with three connections each, the number of face neighbor connections is equal to six. When this token is used, both the <a href="#">FACENEIGHBORMODE</a> token and the FaceNeighbor Connections List are required. Refer to <a href="#">Section "Face Neighbor Connections List"</a> on page 163 for details.
<b>DT</b>	= <datatype> for var1, <datatype> for var2, ..., <datatype> for varn)	N	SINGLE	Each variable in each zone in the data file may have its own data type. The data type determines the amount of storage Tecplot 360 assigns to each variable. Therefore, the lowest level data type should be used whenever possible. For example, imaging data, which usually consists of numerical values ranging from zero to 255, should be given a data type of BYTE. By default, Tecplot 360 treats numeric data as data type SINGLE. If any variable in the zone uses the BIT data type, the <a href="#">DATAPACKING</a> must be BLOCK. Refer to <a href="#">"Data"</a> on page 160 for details.
<b>DATAPACKING</b>	= <datapacking>  >	N	BLOCK	In POINT format, the values for all variables are given for the first point, then the second point, and so on. In BLOCK format, all of the values for the first variable are given in a block, then all of the values for the second variable, then all of the values for the third, and so forth. BLOCK format must be used for cell-centered data and polyhedral zones (FEPOLYGON/FEPOLYHEDRAL), as well as for all binary data.

Keyword	Syntax	Required (Y/N)	Default	Notes
<b>VARLOCATION</b>	<code>=[set-of- vars]=&lt;varlo- cation&gt;,[set- of- vars]=&lt;varlo- cation&gt;, ...)</code>	N	NODAL	Each variable in each zone in a data file may be located at the nodes or the cell-centers. Each variable is specified as NODAL or CELLCENTERED in the VARLOCATION parameter array. All cell-centered variables must list one value for each element. With nodal variables, one value must be listed for each node. Zones with cell-centered variables must be in BLOCK data packing format.
<b>VARSHARELIST</b>	<code>=[set-of- vars]= &lt;zone&gt;,[set- of- vars]=&lt;zone &gt;)</code>	N	If zone number is omitted, the variables are shared from the previous zone.	Used for variables that are exactly the same for a set of zones. Specify the integer value of the source zone. Ordered zones may only share with ordered zones having the same dimensions. Finite element zones may share with any zone having the same number of nodes, for nodal variables, or the same number of cells, for cell-centered data.
<b>NV</b>	<code>= &lt;integer&gt;</code>	N		Specifies the variable number of the variable representing the "Node" value in finite element data. The NV parameter is used infrequently. It is mostly used when the order in which nodes are listed in the data file does not match the node numbering desired in the plot. Refer to <a href="#">Section "Finite Element Zone Node Variable Parameters Example"</a> on page 194 for an example using the NV parameter.
<b>CONNECTIVITYSHAREZONE</b>	<code>=&lt;zone&gt;</code>	N		Specify the number of the zone from which the connectivity is shared. The connectivity list (cell-based finite element only) and face-neighbors may be shared between zones using the CONNECTIVITYSHAREZONE parameter in the control line of the current zone. Alternatively, the parameter may be used to share the <a href="#">Facemap Data</a> for face-based finite element zones. To use connectivity sharing, the zone must have the same number of points and elements (and faces, if the zone is face-based), and be the same zone type.
<b>STRANDID</b>	<code>= &lt;integer&gt;</code>	N		Each zone can optionally specify an integer value associating itself with a particular strand. More than one zone can associate itself with a particular strand and differentiate itself from other zones by assigning different <a href="#">SOLUTIONTIME</a> values. StrandID's must be positive integer values greater than or equal to 1. By convention strandID's are successive integer values.

Keyword	Syntax	Required (Y/N)	Default	Notes
<b>SOLUTIONTIME</b>	= <double>	N		Specify a floating point time value representing the solution time. Zones can be organized together by associating themselves to the same <a href="#">STRANDID</a> .
<b>PARENTZONE</b>	= <zone>	N		Scalar integer value representing the relationship between this zone and its parent. A value of zero indicates that this zone is not associated with a parent zone. A value greater than zero is considered this zone's parent. A zone may not specify itself as its own parent. With a parent zone association, Tecplot 360 can generate a surface streamtrace on a no-slip boundary zone. Refer to <a href="#">Section 15 - 3 "Surface Streamtraces on No-slip Boundaries"</a> in the <a href="#">User's Manual</a> for additional information.
<b>PASSIVEVARLIST</b>	= [set of vars]	N	All variables non-passive	Use this option to make variables passive. For example, to make variables 4, 5, and 20 passive, use this syntax: PASSIVEVARLIST=[4-5,20] See <a href="#">Section 1 - 2 "Best Practices"</a> , <a href="#">Section 6. "Passive Variables"</a> for information on passive variables.
<b>AUXDATA</b>	NAME = <string>	N		Auxiliary data strings associated with the current zone are specified with the AUXDATA parameter in the control line. This auxiliary data may be used in dynamic text, equations, macros, or add-ons. There may be multiple AUXDATA parameters in the control line for a zone, but names must be unique. NOTE: The NAME portion of the string cannot contain spaces. Auxiliary data is provided as named strings: AUXDATA EXPERIMENTDATE ="October 13, 2007, 8 A.M."

## Data

Tecplot 360 supports the following six data types:

- **DOUBLE** (eight-byte floating point values).
- **SINGLE** (four-byte floating point values).
- **LONGINT** (four-byte integer values).
- **SHORTINT** (two-byte integer values).
- **BYTE** (one-byte integer values, from zero to 255).
- **BIT**

The arrangement of ASCII data depends upon the combination of datapacking (BLOCK or POINT), variable location (NODAL or CELL-CENTERED). The zone type also plays a role in that not all forms of datapacking and variable locations are supported by all zone types. In BLOCK data, the data is arranged by variable, while in POINT data the data is arranged by point (node or data point, depending upon the zone type). In NODAL data the variable values are defined at every node (FE data) or point (ORDERED data). In CELLCENTERED data, the variable values are defined at the center of every cell (ORDERED data) or element (FE data).

The available combinations of datapacking and variable location parameters are:

- Block - Nodal
- Block - Cell-centered
- Point - Nodal

The combination of POINT and CELLCENTERED is not available.

### BLOCK - NODAL

In block data with nodal values, the data is arranged by variable and each variable is defined at the nodes. The data arrangement is as follows:

$$\begin{array}{lll}
 \mathbf{A}_{11} & \mathbf{A}_{12} & \dots \mathbf{A}_{1P} \\
 \mathbf{A}_{21} & \mathbf{A}_{22} & \dots \mathbf{A}_{2P} \\
 \cdot & & \\
 \cdot & & \\
 \cdot & & \\
 \mathbf{A}_{V1} & \mathbf{A}_{V2} & \dots \mathbf{A}_{VP}
 \end{array}$$

where:

$\mathbf{V}$  = total number of nonpassive, nonshared variables  
 $\mathbf{P}$  =  $\mathbf{I} * \mathbf{J} * \mathbf{K}$  (ordered zones) or **NODES** (FE zones)

## BLOCK - CELLCENTERED

In block data with cell-centered values, the data is arranged by variable and each variable is defined at the center of each cell (ORDERED data) or element (FE data). The data arrangement is as follows:

$$\begin{array}{lll} \mathbf{A}_{11} & \mathbf{A}_{12} & \dots \mathbf{A}_{1P} \\ \mathbf{A}_{21} & \mathbf{A}_{22} & \dots \mathbf{A}_{2P} \\ \cdot & & \\ \cdot & & \\ \cdot & & \\ \mathbf{A}_{V1} & \mathbf{A}_{V2} & \dots \mathbf{A}_{VP} \end{array}$$

where:

$\mathbf{V}$  = total number of nonpassive, nonshared variables

$\mathbf{P} = (\mathbf{I} - 1) * (\mathbf{J} - 1) * (\mathbf{K} - 1)$  (ordered zones<sup>1</sup>)

or  
 $\mathbf{P} = \mathbf{ELEMENTS}$  (FE zones)

---

1. For all I, J and K greater than one. When I, J or K is equal to one, a value of one is used instead of subtracting one

## POINT - NODAL

In point data, the values for all variables are given for the first point, then the second point and so on. The variable location is always NODAL.

$$\begin{array}{lll} \mathbf{A}_{11} & \mathbf{A}_{12} & \dots \mathbf{A}_{1V} \\ \mathbf{A}_{21} & \mathbf{A}_{22} & \dots \mathbf{A}_{2V} \\ \cdot & & \\ \cdot & & \\ \cdot & & \\ \mathbf{A}_{P1} & \mathbf{A}_{P2} & \dots \mathbf{A}_{PV} \end{array}$$

where:

$\mathbf{V}$  = total number of nonpassive, nonshared variables

$\mathbf{P} = \mathbf{I} * \mathbf{J} * \mathbf{K}$  (ordered zones)

or  
 $\mathbf{P} = \mathbf{ELEMENTS}$  (FE zones)

## General Formatting Rules

The following formatting guidelines apply to all data arrangements:

- Numerical values in zone data must be separated by one or more spaces, commas, tabs, new lines, or carriage returns.
- Blank lines are ignored.
- Integer (**101325**), floating point (**101325 .0**), and exponential (**1 .01325E+05**) numbers are accepted.
- To repeat a particular number in the data, precede it with a repetition number as follows: “*Rep\*Num*,” where *Rep* is the repetition factor and *Num* is some numeric value to be repeated. For example, you may represent 37 values of 120.5 followed by 100 values of 0.0 as follows:

**37\*120.5, 100\*0.0**

### Variable Sharing

Frequently, some variables are exactly the same for a set of zones. For example, a series of zones may contain measurement or simulation data at the same XYZ-locations, but different times. In this case, Tecplot 360’s memory usage may be dramatically reduced by sharing the coordinate variables between the zones. The zones that variables are shared from are specified in the **VARSHARELIST** in the control line of the current zone. The format is:

**VARSHARELIST=([set-of-vars]=zzz, [set-of-vars]=zzz)**

where *set-of-vars* is the set of variables that are shared and *zzz* is the zone they are shared from. If *zzz* is omitted, the variables are shared from the previous zone.

For example:

**VARSHARELIST=([4-6,11]=3, [20-23]=1, [13,15])**

specifies that variables four, five, six and 11 are shared from zone three, variables 20, 21, 22, and 23 are shared from zone one, and variables 13 and 15 are shared from the previous zone. For variable sharing, ordered zones may only share with ordered zones having the same dimensions. Finite element zones may share with any zone having the same number of nodes (for nodal variables) or the same number of cells (for cell-centered data).

### **Zone Footer**

The contents required for the Zone Footer depend upon the **ZONETYPE** (specified in the [Zone Header](#)).

- **Ordered zones** - the Zone Footer contains the [Face Neighbor Connections List](#) (if any).
- **Cell-based finite element zones** (FETRIANGLE, FEQUADILATERAL, FETETRAHEDRAL and FEBRICK) - the Zone Footer contains [Connectivity](#) information, followed by [Face Neighbor Connections List](#) (if any).
- **Face-based finite element zones** (FEPOLYHEDRAL, FEPOLYGON) - the Zone Footer contains [Facemap Data](#), followed by [Boundary Map Data](#).

---

## Connectivity

For cell-based finite element zones (FETRIANGLE, FEQUADILATERAL, FETETRAHEDRAL, and FEBRICK), the nodal data is followed by the connectivity information. The connectivity list is not preceded by a token or keyword. It is simply a list of numbers.

The connectivity list details the node numbers of all of the nodes included in each element. When providing the connectivity list, please keep in mind the following guidelines:

- Each row in the connectivity list corresponds to an element, where the first row corresponds to the first element, and so forth.
- The node numbers must be provided in order, either clockwise or counter-clockwise.
- You must provide the same number of nodes as are included in an element. For example, you must provide eight numbers for BRICK elements and three numbers for TRIANGLE elements. If you are using repeated nodes, provide the node number of the repeated node multiple times.

See also: [“Connectivity Sharing”](#) on page 167.

The connectivity for face-based zones (FEPOLYGON and FEPOLYHEDRAL) is defined by the [Facemap Data](#) (refer to [“Facemap Data”](#) on page 165 for details).

## Face Neighbor Connections List

For ordered zones, the data section may be followed with face neighbor connections. For cell-based finite element zones, the data section and connectivity list may be followed by the face neighbor connection information.

Use face neighbors to specify connections between zones (global connections) or connections within zones (local connections). Face neighbor connections are used by Tecplot when deriving variables or drawing contour lines. Specifying face neighbors, typically leads to smoother connections. NOTE: face neighbors have expensive performance implications. Use face neighbors to manually specify connections that are not defined via the connectivity list.

Face neighbor connections are defined by the [FACENEIGHBORMODE](#) and [FACENEIGHBOR-CONNECTIONS](#) tokens along with the Face Neighbor Connections list. The **FACENEIGHBORMODE** token is used to specify the type of face neighbor connection used. The **FACENEIGHBORCONNECTIONS** token is used to define the total number of face neighbor connections included in the zone.

The nature of the data arranged in the Face Neighbor Connections list depends upon the **FACE-NEIGHBORMODE**, described in the table below. To connect the cells along one edge to cells on another edge of the same zone, use **LOCAL**. To connect cells of one zone to cells of another zone or

zones, use **GLOBAL**. If the points of the cells are exactly aligned with the neighboring cell points, use **ONETOONE**. If even one cell face is neighbor to two or more other cell faces, use **ONETOMANY**.

Mode	Number of Values	Order of Data in the Face Neighbor Connections List
LOCALONETOONE	3	cz, fz, nc
LOCALONETOMANY	$\mathbf{nz+4}$	cz, fz, oz, nz, nc1, nc2, ..., ncn
GLOBALONETOONE	4	cz, fz, zr, cr
GLOBALONETOMANY	$\mathbf{2*nz+4}$	cz, fz, oz, nz, zr1, cr1, zr2, cr2, ..., zrn, crn

In this table,

- **cz** -the cell number in the current zone
- **fz** - the number of the cell face in the current zone
- **nc** -the cell number of the neighbor cell in the current zone
- **oz** - face obscuration flag (zero for face partially obscured, one for face entirely obscured)
- **nz** - the number of neighboring cells for the **ONETOMANY** options
- **ncn** - the number of the *n*th local zone neighboring cell in the list
- **zr** - the remote zone number
- **cr** - the cell number of the neighboring cell in the remote zone
- **zrn** - the zone number of the *n*th neighboring cell in the **GLOBALONETOMANY** list
- **crn** - the cell number in the remote zone of the *n*th neighboring cell in the **GLOBALONETOMANY** list.

The **cz**, **fz** combinations must be unique; multiple entries are not allowed. The face numbers for cells in the various zone types are defined in [Figure 4-1](#).

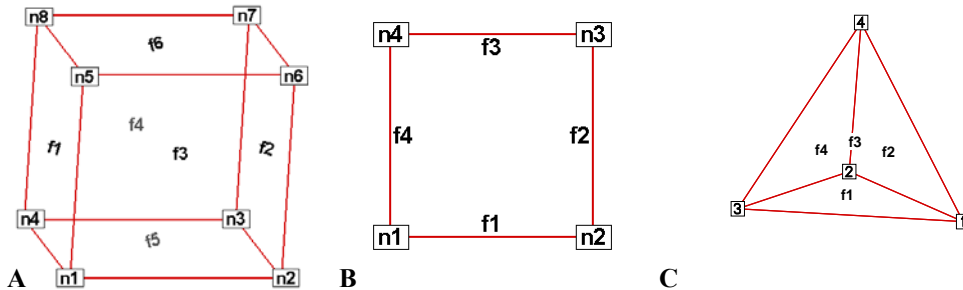

*Figure 4-1.* **A:** Example of node and face neighbors for an fe-brick cell or IJK-ordered cell. **B:** Example of node and face numbering for an IJ-ordered cell. **C:** example of tetrahedron face neighbors.

A connection must be specified for two matching cell faces to be effective. The nature of the Face Neighbor Connections list depends upon its **FACENEIGHBORMODE**.

For example, for data with a **FACENEIGHBORMODE** of **GLOBALONETOONE**, if cell six, face two in zone nine should be connected to cell one, face four in zone 10, the connections for zone nine must include the line:

```
6 2 10 1 (cell#, face#, connecting zone#, connecting cell#)
```

And the connections for zone 10 must include this line:

```
1 4 9 6 (cell#, face#, connecting zone#, connecting cell#)
```

Global face neighbors are useful for telling Tecplot 360 about the connections between zones. This could be used, for example, to smooth out the crease in Gouraud surface shading at zone boundaries. For cell-centered data, they can make contours and streamtraces more continuous at zone boundaries.

### Facemap Data

For face-based finite element zones (**FEPOLYGON** and **FEPOLYHEDRAL**), the data section is followed by the Facemap Data section. If boundary faces are used, the Facemap Data section is followed by the [Boundary Map Data](#) data section. Otherwise, the facemap data section marks the end of the zone record.

The face map data (in four major groupings) is defined by the following list:



Like the Data section of the zone record, the data region of the Face Map section does not include tokens. It includes a list of data. The descriptors `TotalNodesInFace`, `WhichNodesInFace`, `LeftNeighborForFace` and `RightNeighborForFace` should not be included in your data file.

1. **TotalNodesInFace** - A space-separated list of the total number of nodes in each face:

*NodesInFace<sub>1</sub> NodesInFace<sub>2</sub> ...NodesInFace<sub>F</sub>*

where F is equal to the total number of faces.

NOTE: The `TotalNodesInFace` section is not used for polygonal zones, as each face of a polygon always has two nodes.

2. **WhichNodesInFace** - A list of the node numbers for each node in each face. Use a separate line for each face.

*Face<sub>1</sub>Node<sub>1</sub> Face<sub>1</sub>Node<sub>2</sub> ...Face<sub>1</sub>Node<sub>TotalNodesInFace1</sub>*

*Face<sub>2</sub>Node<sub>1</sub> Face<sub>2</sub>Node<sub>2</sub> ...Face<sub>2</sub>Node<sub>TotalNodesInFace2</sub>*

...

*Face<sub>F</sub>Node<sub>1</sub> Face<sub>F</sub>Node<sub>2</sub> ...Face<sub>F</sub>Node<sub>TotalNodesInFaceF</sub>*

3. **LeftNeighborForFace** - A list of left neighboring elements for each face:

*LeftElementForFace<sub>1</sub> LeftElementForFace<sub>2</sub> ... LeftElementForFace<sub>F</sub>*

4. **RightNeighborForFace** -A list of right neighboring elements for each face:

*RightElementForFace<sub>1</sub> RightElementForFace<sub>2</sub> ... RightElementForFace<sub>F</sub>*



The face map may be shared between zones in the same file by specifying the zone number of the sharing zone in place of the [CONNECTIVITYSHAREZONE](#) value.

### Defining Neighboring Elements

The left element and right element are determined by the left-hand versus right-hand winding rule. The left and right neighboring elements represent elements within the current zone, and they are always "one-to-one". That is, each face represents a complete interface between two elements. A negative value (-) in either of the neighboring faces lists indicates that the neighboring element(s) are defined in the boundary face section at the  $t^{\text{th}}$  boundary face. Refer to [Section "Boundary Map Data"](#) for details.

Any face that has no neighboring element for either its right or left adjacent element, will use a value of zero for the element value.

See also ["Connectivity Sharing"](#) on page 167.

### Boundary Map Data

If the [NUMCONNECTEDBOUNDARYFACES](#) is greater than zero, the boundary map data section is required. The boundary map data section should immediately follow the [Facemap Data](#) section. This section does not need to be "one-to-one". One face can link up to multiple elements in other zones.

The number of adjacent elements is listed for each of the boundary faces. Then each boundary face lists the element number for each of its adjacent elements. Then each boundary face lists the zone number for each of its adjacent elements. The number of the face is not specified but is implicit (first face listed is 1 and corresponds to -1 in the left/right neighbor list, the second is 2 and corresponds to -2, etc.).

### Connectivity Sharing

The connectivity list and face neighbor connections (for cell-based finite element zones) or the facemap data (for face-based finite element zones) may be shared between zones by using the **CONNECTIVITYSHAREZONE** parameter in the control line of the current zone. The format is:

```
CONNECTIVITYSHAREZONE=nnn
```

where *nnn* is the number of the zone that the connectivity is shared from. To use connectivity sharing, the zone must have the same number of points and elements, and be the same zone type.

## 4- 3.3 Text Record

Text records are used to import text directly from a data file. Text can also be imported into Tecplot 360 using a macro file. You may create data files containing only text records and read them into Tecplot 360 just as you would read any other data file. You may delete and edit text originating from data files just like text created interactively.

The text record consists of a single control line. The control line starts with the keyword **TEXT** and has one or more options:

## Text Record:

Token	Syntax	Required (Y/N)	Default	Notes
<b>TEXT</b>		Y		Keyword required to start a text record
<b>T</b>	= <string>	Y		The text string is defined in the required <b>T</b> (text) parameter. To include multiple lines of text in a single text record, include <code>\\n</code> in the text string to indicate a new line.
<b>ZN</b>	= <integer>	N		Use the <b>ZN</b> ( <i>zone</i> ) parameter to attach text to a specific zone or XY mapping. For further information, see <a href="#">Section 18-1.2 “Text Options”</a> in the <a href="#">User’s Manual</a> .
<b>X</b>	= <double>	Y		Specify the x-origin, y-origin and z-origin of the object. The x-origin and y-origin should be in <b>CS</b> (coordinatesys) units. The z-origin of object must always in GRID units.
<b>Y</b>	= <double>	Y		
<b>Z</b>	= <double>	Y		
<b>R</b>	= <double>	Y		r-origin (in <b>CS</b> units) of the object
<b>THETA</b>	= <double>	Y		theta-origin (in <b>CS</b> units) of the object
<b>CS</b>	= <a href="#">&lt;coordinatesys&gt;</a>	N	FRAME	Text coordinate system. If you specify the frame coordinate system, the values of the <b>X</b> (xorigin) and <b>Y</b> (yorigin) parameters are in frame units; if you specify grid coordinates, <b>X</b> and <b>Y</b> are in grid units (that is, units of the physical coordinate system). Specify <b>X</b> , <b>Y</b> and <b>Z</b> for <b>GRID3D</b> coordinates. For Polar Line plots, you may specify <b>THETA</b> and <b>R</b> instead of <b>X</b> and <b>Y</b> .
<b>A</b>	= <double>	N		Use the <b>A</b> parameter to rotate the text box at an angle counter-clockwise from horizontal. The angle is in units of degrees.
<b>S</b>	= <a href="#">&lt;scope&gt;</a>	N		Scope of the text box. <b>GLOBAL</b> scope attaches the text box to all frames using the same data set. It is the same as selecting the check box <i>Show in “Like” Frames</i> in the <b>Text Options</b> dialog.
<b>BX</b>	= <a href="#">&lt;boxtype&gt;</a>	N	NOBOX	Draw a box around the text string using the <b>BX</b> (boxtype) parameter. The parameters <b>BXO</b> (boxoutlinecolor), <b>BXM</b> (boxmargin), and <b>LT</b> (linethickness) are used if the boxtype is <b>HOLLOW</b> or <b>FILLED</b> . The parameter <b>BXF</b> (boxfillcolor) is used only if the boxtype is <b>FILLED</b> . The default boxtype, <b>NOBOX</b> , ignores all other box parameters.
<b>BXF</b>	= <a href="#">&lt;color&gt;</a>	N		Box Fill Color; <b>BX</b> (boxtype) must be set to <b>FILLED</b> .
<b>BXM</b>	= <double>	N		When <b>BX</b> (boxtype) is set to <b>HOLLOW</b> or <b>FILLED</b> , use the <b>BXM</b> token to specify the margin around text in box as fraction of <b>H</b> ( <i>text height</i> ).
<b>BXO</b>	= <a href="#">&lt;color&gt;</a>	N		When <b>BX</b> (boxtype) is set to <b>HOLLOW</b> or <b>FILLED</b> , use the <b>BXO</b> token to specify the color of the box outline.
<b>LT</b>	= <double>			When <b>BX</b> (boxtype) is set to <b>HOLLOW</b> or <b>FILLED</b> , use the <b>LT</b> token to specify the thickness of the box outline.
<b>F</b>	= <a href="#">&lt;font&gt;</a>	N		Use the <b>F</b> parameter to specify the font family.
<b>C</b>	= <a href="#">&lt;color&gt;</a>	N		Font color.
<b>AN</b>	= <a href="#">&lt;textanchor&gt;</a>			Use the <b>AN</b> (textanchor) parameter to specify the position of the anchor point relative to the text. There are nine possible anchor positions, as shown in <a href="#">Figure 4-2</a> .

Token	Syntax	Required (Y/N)	Default	Notes
<b>LS</b>	= <double>	N	1	Assign the line spacing for multi-line text using the <b>LS</b> (linespacing) parameter. The default value, 1, gives single-spacing. Use 1.5 for line-and-a-half spacing, 2 for double-spacing, and so on.
<b>H</b>	= <double>			Specify the height, measured in the units defined by <b>HU</b> .
<b>HU</b>	= <heightunits>			Units for character heights. If the <b>CS</b> parameter is <b>FRAME</b> , you can set <b>HU</b> to either <b>FRAME</b> or <b>POINT</b> . If the <b>CS</b> parameter is <b>GRID</b> , you can set <b>HU</b> to either <b>GRID</b> or <b>FRAME</b> .
<b>MFC</b>	= <string>			Attach a macro function to the text. The macro function must be a retained macro function that was either set during the current Tecplot session or included in the <i>tecplot.mcr</i> file. Refer to <a href="#">Section 18 - 5 "Text and Geometry Links to Macros"</a> in the <i>User's Manual</i> and <a href="#">"\$!MACROFUNCTION...\$!ENDMACROFUNCTION"</a> in the <i>Scripting Guide</i> for additional information.
<b>CLIPPING</b>	= <clipping>			Plot the geometry within to the viewport or the frame.

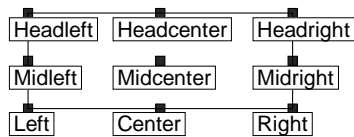

Figure 4-2. Text anchor positions—values for the **AN** parameter.

### Text Record Examples

Some simple examples of text records are shown below. The first text record specifies only the origin and the text. The next text record specifies the origin, color, font, and the text. The third text record specifies the origin, height, box attributes, and text. Note that the control line for the text can span multiple file lines if necessary (as in the third text record below). The last text record is an example of using 3D text in Tecplot 360.

```
TEXT X=50, Y=50, T="Example Text"
TEXT X=10, Y=10, F=TIMES-BOLD, C=BLUE, T="Blue Text"
TEXT X=25, Y=90, CS=FRAME, HU=POINT, H=14,
BX=FILLED, BXF=YELLOW, BXO=BLACK, LS=1.5,
T="Box Text \\n Multi-lined text"
TEXT CS=GRID3D, X=0.23,Y=0.23,Z=0.5, T="Well 1"
```

### 4- 3.4 Geometry Record

Geometry records are used to import geometries from a data file. Geometries are line drawings that may be boundaries, arrows, or even representations of physical structures. You may create data files containing only geometry and text records and read them into Tecplot 360. You may delete and edit geometries originating from data files just like the geometries that you create interactively.

The geometry record control line begins with the keyword **GEOMETRY**.

#### Geometry Record Contents:

Token	Available Values	Notes
<b>GEOMETRY</b>		Keyword required to start a geometry record
<b>T</b>	= <a href="#">&lt;geomtype&gt;</a>	Geometry type
<b>F</b>	= <a href="#">&lt;datapacking&gt;</a>	Geometry data format
<b>DT</b>	= <a href="#">&lt;datatype&gt;</a>	Data type
<b>ZN</b>	= <a href="#">&lt;integer&gt;</a>	Attach text to a specific zone or XY mapping. For further information, see <a href="#">Section 18- 1.2 “Text Options”</a> in the <a href="#">User’s Manual</a> .
<b>X</b>	= <a href="#">&lt;double&gt;</a>	Specify the x-origin, y-origin and z-origin of the object. The x-origin and y-origin should be in <a href="#">CS</a> (coordinatesys) units. The z-origin of object is for LINE3D geometries only and must always in GRID units. Refer to <a href="#">Section “Origin positions”</a> on page 172 for additional information regarding the origin location for each type of geometry.
<b>Y</b>	= <a href="#">&lt;double&gt;</a>	
<b>Z</b>	= <a href="#">&lt;double&gt;</a>	
<b>R</b>	= <a href="#">&lt;double&gt;</a>	Specify the r-origin and theta-origin of the object. The origins should be in <a href="#">CS</a> units. Refer to <a href="#">Section “Origin positions”</a> on page 172 for additional information.
<b>THETA</b>	= <a href="#">&lt;double&gt;</a>	
<b>CS</b>	= <a href="#">&lt;coordinatesys&gt;</a> >=	Geometry coordinate system . If you specify the frame coordinate system, the values of the <b>X</b> (xorigin) and <b>Y</b> (yorigin) parameters are in frame units; if you specify grid coordinates, <b>X</b> and <b>Y</b> are in grid units (that is, units of the physical coordinate system). Specify <b>X</b> , <b>Y</b> and <b>Z</b> for <b>GRID3D</b> coordinates. For Polar Line plots, you may specify <b>THETA</b> and <b>R</b> instead of <b>X</b> and <b>Y</b> .
<b>DRAWORDER</b>	= <a href="#">&lt;draworder&gt;</a>	Draw order.

Token	Available Values	Notes
<b>S</b>	= <a href="#">&lt;scope&gt;</a>	The <b>S</b> ( <i>scope</i> ) parameter specifies the text scope. <b>GLOBAL</b> scope attaches the text box to all frames using the same data set. It is the same as selecting the check box <i>Show in "Like" Frames</i> in the <b>Geometry Options</b> dialog.
<b>C</b>	= <a href="#">&lt;color&gt;</a>	Geometry outline color.
<b>L</b>	= <a href="#">&lt;linetype&gt;</a>	Line type
<b>PL</b>	= <a href="#">&lt;double&gt;</a>	Pattern length (in frame units).
<b>LT</b>	= <a href="#">&lt;double&gt;</a>	Line thickness (in frame units)
<b>EP</b>	= <a href="#">&lt;integer&gt;</a>	Number of points used to approximate circles or ellipses
<b>FC</b>	= <a href="#">&lt;color&gt;</a>	Fill Color. Any geometry type except LINE3D may be filled with a color by using the FC (fillcolor) parameter. Each polyline of a LINE geometry is filled individually (by connecting the last point of the polyline with the first). Not specifying the FC (fillcolor) parameter results in a hollow, or outlined, geometry drawn in the color of the C (color) parameter.
<b>AST</b>	= <a href="#">&lt;arrowheadstyl e&gt;</a>	Arrowhead style
<b>AAT</b>	= <a href="#">N&lt;arrowheadattach&gt;</a>	Arrowhead attachment along the line geometry
<b>ASZ</b>	= <a href="#">&lt;double&gt;</a>	Size of arrowhead in frame units
<b>AAN</b>	= <a href="#">&lt;double&gt;</a>	Angle of arrowhead in degrees
<b>MFC</b>	= <a href="#">&lt;string&gt;</a>	You may attach a macro function to the text with the <b>MFC</b> parameter. The macro function must be a retained macro function that was either set during the current Tecplot session or included in the <i>tecplot.mcr</i> file. Refer to <a href="#">Section 18 - 5 "Text and Geometry Links to Macros"</a> in the <a href="#">User's Manual</a> and <a href="#">"\$!MACROFUNCTION...\$!ENDMACROFUNCTION"</a> on page 187 in the <a href="#">Scripting Guide</a> for additional information.
<b>CLIPPING</b>	= <a href="#">&lt;clipping&gt;</a>	plot the geometry within the viewport or the frame.

## Data for Geometry Record

The control line of the geometry is followed by geometry data. For **SQUARE**, the geometry data consists of just one number: the side length of the square.

For **RECTANGLE**, the geometry data consists of two numbers: the first is the width (horizontal axis dimension), and the second is the height (vertical axis dimension).

For **CIRCLE**, the geometry data is one number: the radius. For **ELLIPSE**, the geometry data consists of two numbers: the first is the horizontal axis length and the second is the vertical axis length. For both circles and ellipses, you can use the **EP** (*numellipsepts*) parameter to specify the number of points used to draw circles and ellipses. All computer-generated curves are simply collections of very short line segments; the **EP** parameter allows you to control how many line segments Tecplot 360 uses to approximate circles and ellipses. The default is 72.

For **LINE** and **LINE3D** geometries, the geometry data is controlled by the **F** (*format*) parameter. These geometries may be specified in either **POINT** or **BLOCK** format. By default, **POINT** format is assumed. Each geometry is specified by the total number of polylines, up to a maximum of 50 polylines, where each polyline can have up to 32,000 points. Each polyline is defined by a number of points and a series of XY- or XYZ- coordinate points between which the line segments are drawn. In **POINT** format, the XY- or XYZ-coordinates are given together for each point. In **BLOCK** format, all the X-values are listed, then all the Y-values, and (for **LINE3D** geometries) all the Z-values. All coordinates are relative to the **x**, **y**, and **z** specified on the control line. You can specify points in either single or double precision by setting the **DT** (*datatype*) parameter to either **SINGLE** or **DOUBLE**.

## Origin positions

Geometry types are selected with the **T** (*geomtype*) parameter. The available geometry types are listed below:

- **SQUARE** - A square with lower left corner at **x**, **y**
- **RECTANGLE** - A rectangle with lower left corner at **x**, **y**
- **CIRCLE** - A circle centered at **x**, **y**
- **ELLIPSE** - An ellipse centered at **x**, **y**
- **LINE** - A set of 2D polylines (referred to as multi-polylines) anchored at **x**, **y**
- **LINE3D** - A set of 3D polylines (referred to as multi-polylines) anchored at **x**, **y**, **z**.

## Geometry Record Examples

- **Rectangle** - The following geometry record defines a rectangle of **40** width and **30** height:

```
GEOMETRY T=RECTANGLE
40 30 #WIDTH HEIGHT
```

- **Circle** - The following geometry record defines an origin and a red circle of **20** radius, with an origin of (75, 75) that is filled with blue:

```
GEOMETRY X=75, Y=75, T=CIRCLE, C=RED, FC=BLUE,CS=FRAME
```

20 #RADIUS

- **Polyline** - The following geometry record defines an origin and two polylines, drawn using the Custom 3 color. The first polyline is composed of three points, the second of two points.

```
GEOMETRY X=50, Y=50, T=LINE, C=CUST3
2          #Number of polylines
3          #Number of points in polyline 1
0 1       #X, Y coordinates of the point 1 in polyline 1
0 0       #X, Y coordinates of the point 2 in polyline 1
2 0       #X, Y coordinates of the point 3 in polyline 1
2          #Number of points in polyline 2
0 0       #X, Y coordinates of the point 1 in polyline 2
1 2       #X, Y coordinates of the point 2 in polyline 2
```

In **BLOCK** format, the same geometry appears as:

```
GEOMETRY X=50, Y=50, T=LINE, C=CUST3, F=BLOCK, CS=FRAME
2          #Number of polylines
3          #Number of points in polyline 1
0 0 2     #X position of each point in polyline 1
1 0 0     #Y position of each point in polyline 1
2          #Number of points in polyline 2
0 1       #X position of each point in polyline 2
0 2       #y position of each point in polyline 2
```

- **Ellipse** - The next geometry record defines a purple ellipse with a horizontal axis length of 20 and a vertical axis length of 10, with an origin of (10, 70), that is filled with yellow.

```
GEOMETRY X=10, Y=70, T=ELLIPSE, C=PURPLE, FC=YELLOW
20 10     #Horizontal Axis, Vertical Axis
```

- **3D polyline** - The final geometry record is a 3D polyline with four points that is composed of one polyline using the default origin of (0, 0, 0):

```
GEOMETRY T=LINE3D
1          #Number of polylines
4          #Number of points in polyline 1
0 0 0     #X, Y, Z coordinates of point 1
1 2 2     .
3 2 3     .
4 1 2     #X, Y, Z coordinates of point 4
```

In **BLOCK** format, this geometry record can be written as follows:

```
GEOMETRY T=LINE3D, F=BLOCK
1          #Number of polylines
4          #Number of points in polyline 1
0 1 3 4   #X position for each point in the polyline
0 2 2 1   #Y position for each point in the polyline
0 2 3 2   #Z position for each point in the polyline
```

### 4- 3.5 Custom Labels Record

The custom label record is an optional record used to provide custom labels for axes, the contour legend or value labels. A single custom label record begins with the keyword **CUSTOMLABELS**, followed by a series of text strings. The first custom label string corresponds to a value of one on the axis, the next to a value of two, and so forth.

You may have up to ten custom label records in a data file. The custom label set to use is specified via the Tecplot interface. Refer to [Section 17- 7.1 “Creating Custom Labels”](#) in the [User’s Manual](#) for details.

A simple example of a custom-label record is shown below. **MON** corresponds to a value of **1**, **TUE** corresponds to **2**, **WED** to **3**, **THU** to **4**, and **FRI** to **5**. Since custom labels have a wrap-around effect, **MON** also corresponds to the values **6**, **11**, and so forth.

```
CUSTOMLABELS "MON", "TUE", "WED", "THU", "FRI"
```

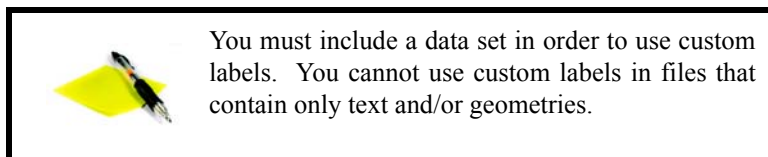

### 4- 3.6 Data Set Auxiliary Data Record

There is frequently auxiliary data (or Metadata) that helps describe the data set. For example, experimental data may have information about the facility and time at which the data was taken, and other parameters that describe the experiment. Likewise, simulation results have auxiliary data (such as reference quantities for non-dimensional data) needed to fully analyze and present the results.

Auxiliary data are name/value pairs that a user can specify and then use in Tecplot 360 with dynamic text, equations, macros, or add-ons. This data may be with respect to the data set as a whole or it can vary from zone to zone. The ASCII file format token for specifying auxiliary data associated with the entire data set is DATASETAUXDATA, described here. Auxiliary data for a given variable is defined by VARAUXDATA, described in [Section 4- 3.7 “Variable Auxiliary Data Record”](#). Auxiliary data for a given zone is defined by the [AUXDATA](#) token within the zone record (refer to [“Zone Header”](#) on page 156 for details).

The data set auxiliary data control line is as follows:

```
DATASETAUXDATA name = "value"
```

where name is a unique character string with no spaces. You may have multiple **DATASETAUXDATA** records. However, the value of name must be unique for each record.

Auxiliary data may be used in text, macros, equations (if it is numeric), and accessed from add-ons. It may also be viewed directly in the *AuxData* page of the **Data Set Information** dialog.

### *Data Set Auxiliary Data Examples*

The following auxiliary data contain flow field information that might be found in output from a computational fluid-dynamics simulation.

```
DATASETAUXDATA MachNo = "1.2"
DATASETAUXDATA Alpha = "5"
DATASETAUXDATA RefTemperature = "250"
DATASETAUXDATA RefPressure = "101325"
DATASETAUXDATA Configuration = "A2 No. 3"
```

```
DATASETAUXDATA Date = "August 5, 2003"
DATASETAUXDATA Region = "NE Quadrant of Sector 47"
```

You may then use the numerical values in equations to modify the variables as follows:

```
{P} = {P_non_dim} * AuxDataSet:RefPressure
```

Similar principles apply when using auxiliary data in text boxes or labels.

### 4- 3.7 Variable Auxiliary Data Record

Variable auxiliary data is added to Tecplot 360 on a per variable basis. Like dataset auxiliary data, multiple items can be added for each variable:

```
VARAUXDATA 1 MyData="Hello"
VARAUXDATA 1 MoreData="World"
VARAUXDATA 2 MyData="More information"
VARAUXDATA 2 MoreData="hi mom"
VARAUXDATA 2 MyExtraData="Some extra data"
```

The variable number with which the auxiliary data is associated immediately follows the VARAUXDATA record. Also note that the data associated with a particular auxiliary data name are unique for each variable. Therefore the same named item can be added to each variable if desired. Conversely a particular auxiliary data item can be added to only one variable. NOTE: The name of an auxiliary data record cannot contain spaces.

### 4- 3.8 ASCII Data File Parameter Assignment Values

The following parameters assignment values are shared among the following types of ASCII file records: [Zone Record](#), [Text Record](#), and/or [Geometry Record](#). Refer to those sections for details.

<i>&lt;arrowheadstyle&gt;</i>	PLAIN, HOLLOW, FILLED
<i>&lt;arrowheadattach&gt;</i>	NONE, BEGINNING, END, BOTH
<i>&lt;boxtype&gt;</i>	NOBOX, HOLLOW, FILLED
<i>&lt;clipping&gt;</i>	CLIPTOVIEWPORT, CLIPTOFRAME
<i>&lt;color&gt;</i>	BLACK, RED, GREEN, BLUE, CYAN, YELLOW, PURPLE, WHITE, CUST1, ... , CUST8
<i>&lt;coordinatesys&gt;</i>	FRAME, GRID, GRID3D
<i>&lt;datapacking&gt;</i>	BLOCK, POINT
<i>&lt;datatype&gt;</i>	SINGLE, DOUBLE
<i>&lt;draworder&gt;</i>	AFTERDATA, BEFOREDATA
<i>&lt;font&gt;</i>	HELV, HELV-BOLD, TIMES, TIMES-ITALIC, TIMES-BOLD, TIMES-ITALIC-BOLD, COURIER, COURIER-BOLD, GREEK, MATH, USER-DEF
<i>&lt;geomtype&gt;</i>	LINE, SQUARE, RECTANGLE, CIRCLE, ELLIPSE
<i>&lt;heightunits&gt;</i>	In FRAME coordinatesys either FRAME or POINT; in GRID coordinatesys either GRID or FRAME.

<code>&lt;linetype&gt;</code>	SOLID, DASHED, DASHDOT, DOTTED, LONGDASH, DASHDOTDOT
<code>&lt;scope&gt;</code>	GLOBAL, LOCAL
<code>&lt;textanchor&gt;</code>	LEFT, CENTER, RIGHT, MIDDLEFT, MIDCENTER, MIDRIGHT, HEADLEFT, HEADCENTER, HEADRIGHT
<code>&lt;varlocation&gt;</code>	NODAL, CELLCENTERED
<code>&lt;zone&gt;</code>	zone number to which this item is assigned (0=all)
<code>&lt;zonetype&gt;</code>	ORDERED, FELINESEG, FETRIANGLE, FEQUADRILATERAL, FETETRAHEDRON, FEBRICK, FEPOLYGON or FEPOLYHEDRAL

## 4 - 4 Ordered Data

For ordered data, the numerical values in the zone data must be in either **POINT** or **BLOCK** format, specified by the **DATAPACKING** parameter.

### 4- 4.1 I-Ordered Data

I-ordered data has only one index, the I-index. This type of data is typically used for XY-plots, scatter plots, and irregular (random) data for triangulation or for interpolation into an IJ-or IJK-ordered zone within Tecplot 360.

In I-ordered data, the I-index varies from one to  $IMax$ . The total number of data points is  $IMax$ . For zones with only nodal variables, the total number of values in the zone data is  $IMax * N$  (where  $N$  is the number of variables). For a mixture of nodal and cell-centered variables, the number of values in the zone data is  $IMax * Nn + (IMax - 1) * Nc$ , where  $Nn$  is the number of nodal variables and  $Nc$  is the number of cell-centered variables. For data in **POINT** format,  $IMax$  is calculated by Tecplot 360 from the zone data if it is not explicitly set by the zone control line (using the  $\tau$ -parameter).

### 4- 4.2 IJ-Ordered Data

IJ-ordered data has two indices: I and J. IJ-ordered data is typically used for 2D and 3D surface mesh, contour, vector, and shade plots, but it can also be used to plot families of lines in XY-plots. Refer to [Chapter 3 “Data Structure”](#) in the [User’s Manual](#) for more information on data structure. In IJ-ordered data, the I-index varies from one to  $IMax$ , and the J-index varies from one to  $JMax$ . The total number of data points (nodes) is  $IMax * JMax$ . For zones with only nodal variables, the total number of numerical values in the zone data is  $IMax * JMax * N$  (where  $N$  is the number of variables). For a mixture of nodal and cell-centered variables, the number of values in the zone data is  $IMax * JMax * Nn + (IMax - 1) * (JMax - 1) * Nc$ , where  $Nn$  is the number of nodal variables and  $Nc$  is the number of cell-centered variables. Both  $IMax$  and  $JMax$  must be specified in the zone control line (with the  $\tau$  and  $\sigma$  parameters). The I- and J-indices should not be confused with the X- and Y-coordinates—on occasions the two may coincide, but this is not the typical case.

The I-index varies the fastest. That is, when you write programs to print IJ-ordered data, the I-index is the inner loop and the J-index is the outer loop. Note the similarity between I-ordered data and IJ-ordered data with  $JMax = 1$ .

---

### 4- 4.3 IJK-Ordered Data

IJK-ordered data has three indices: I, J, and K. This type of data is typically used for 3D volume plots, although planes of the data can be used for 2D and 3D surface plots. See [Section 3 - 2 “Ordered Data”](#) in the [User’s Manual](#) for more information.

In IJK-ordered data, the I-index varies from one to  $IMax$ , the J-index varies from one to  $JMax$ , and the K-index varies from one to  $KMax$ . The total number of data points (nodes) is  $IMax * JMax * KMax$ . For zones with only nodal variables the total number of values in the zone data is  $IMax * JMax * KMax * N$ , where  $N$  is the number of variables. For a mixture of nodal and cell-centered variables, the number of values in the zone data is  $IMax * JMax * KMax * Nn + (IMax - 1) * (JMax - 1) * (KMax - 1) * Nc$ , where  $Nn$  is the number of nodal variables and  $Nc$  is the number of cell-centered variables. The three indices,  $IMax$ ,  $JMax$ , and  $KMax$ , must be specified in the zone control line using the **I**-, **J**-, and **K**-parameters.

The I-index varies the fastest; the J-index the next fastest; the K-index the slowest. If you write a program to print IJK-ordered data, the I-index is the inner loop, the K-index is the outer loop, and the J-index is the loop in between. Note the similarity between IJ-ordered data and IJK-ordered data with  $KMax=1$ .

### 4- 4.4 Ordered Data Examples

The following examples are provided for your reference:

- [I-Ordered Data - Simple example](#)
- [IJ-Ordered Data - Simple Example](#)
- [IJK-Ordered Data - Simple Example](#)
- [Multi-Zone XY Line Plot](#)
- [Multi-Zone XY Line Plot with Variable Sharing Example](#)
- [Cell-Centered Data](#)
- [Two-Dimensional Field Plots](#)
- [Three-Dimensional Field Plots](#)
- [Polygonal - simple example](#)
- [Polyhedral - complex example](#)

### *I-Ordered Data - Simple example*

This data set is plotted in [Figure 4-3](#); each data point is labeled with its I-index.

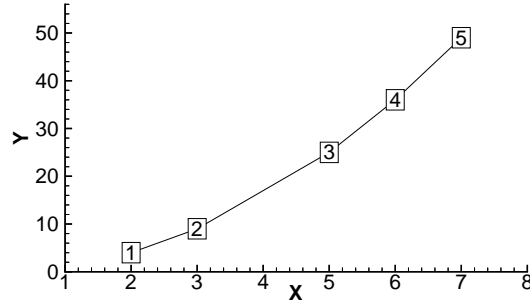

Figure 4-3. An I-ordered data set.

In this example, each column of zone data corresponds to a data point; each row to a variable.

```
VARIABLES = "X", "Y"
ZONE I=5, DATAPACKING=BLOCK
2 3 5 6 7
4 9 25 36 49
```

In **BLOCK** format all values of each variable are listed, one variable at a time.

### FORTRAN Code

The following sample FORTRAN code shows how to create I-ordered data in **BLOCK** format:

```
INTEGER VAR
.
.
.
WRITE (*,*) 'ZONE DATAPACKING=BLOCK, I=', IMAX
DO 1 VAR=1, NUMVAR
DO 1 I=1, IMAX
WRITE (*,*) ARRAY (VAR, I)
1 CONTINUE
```

## *IJ-Ordered Data - Simple Example*

There are four variables (**X**, **Y**, **Temperature**, **Pressure**) and six data points.

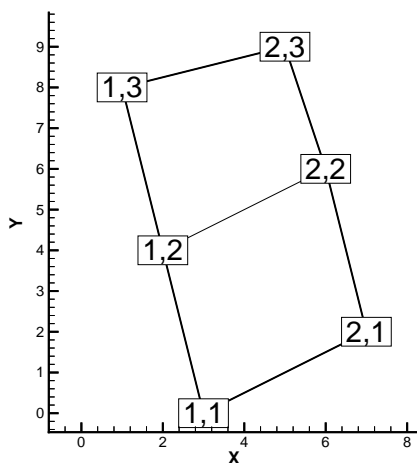

Figure 4-4. An IJ-ordered data set.

In this example, each column of data corresponds to a data point; each row to a variable.

```
VARIABLES = "X", "Y", "Temperature", "Pressure"
ZONE I=2, J=3, DATAPACKING=BLOCK
3 7 2 6 1 5
0 2 4 6 8 9
0 0 1 0 1 1
50 43 42 37 30 21
```

In **BLOCK** format, all  $IMax * JMax$  values of each variable are listed, one variable at a time. Within each variable block, all the values of a variable at each data point are listed.

### FORTRAN Code

The following sample FORTRAN code shows how to create IJ-ordered data in **BLOCK** format:

```
INTEGER VAR
.
.
.
WRITE (*,*) 'ZONE DATAPACKING=BLOCK, I=', IMAX, ', J=', JMAX
DO 1 VAR=1, NUMVAR
DO 1 J=1, JMAX
DO 1 I=1, IMAX
WRITE (*,*) ARRAY (VAR, I, J)
1 CONTINUE
```

### *IJK-Ordered Data - Simple Example*

An example of IJK-ordered data in **BLOCK** format is listed below. There are four variables (**x**, **y**, **z**, **Temperature**) and twelve data points. This data is plotted in [Figure 4-5](#); each data point is labeled with its IJK-index.

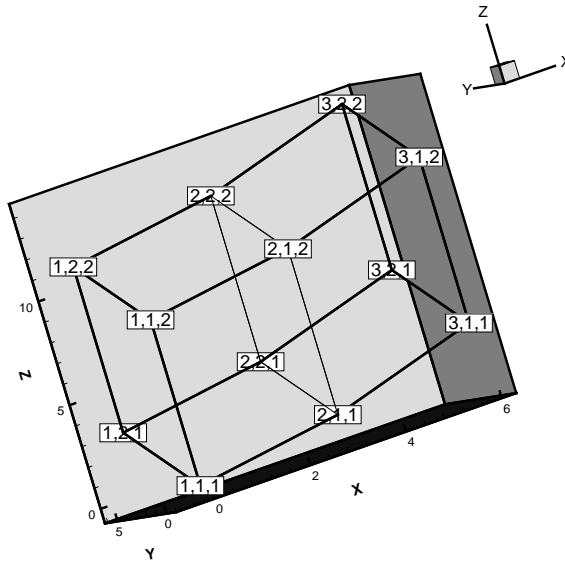

Figure 4-5. An IJK-ordered data set.

For this example, each column of data corresponds to a data point; each row to a variable.

```
VARIABLES = "X" "Y" "Z" "Temp"
ZONE I=3, J=2, K=2, DATAPACKING=BLOCK
0 3 6 0 3 6 0 3 6 0 3 6
0 0 0 6 6 6 0 0 0 6 6 6
0 1 3 3 4 6 8 9 11 11 12 14
0 5 10 10 41 72 0 29 66 66 130 169
```

### FORTRAN Code

The following sample FORTRAN code shows how to create an IJK-ordered zone in **BLOCK** format:

```
INTEGER VAR
.
.
.
WRITE (*,*) 'ZONE DATAPACKING=BLOCK, I=', IMAX, ', J=', JMAX, ', K=', KMAX
DO 1 VAR=1, NUMVAR
DO 1 K=1, KMAX
```

```

DO 1 J=1, JMAX
DO 1 I=1, IMAX
WRITE (*,*) ARRAY (VAR, I, J, K)
1 CONTINUE

```

### Multi-Zone XY Line Plot

The two tables below show the values of pressure and temperature measured at four locations on some object at two different times. The four locations are different for each time measurement.

Time = 0.0 seconds:		
Position	Temperature	Pressure
71.30	563.7	101362.5
86.70	556.7	101349.6
103.1	540.8	101345.4
124.4	449.2	101345.2

Time = 0.1 seconds:		
Position	Temperature	Pressure
71.31	564.9	101362.1
84.42	553.1	101348.9
103.1	540.5	101344.0
124.8	458.5	101342.2

For this case, we want to set up two zones in the data file, one for each time value. Each zone has three variables (**Position**, **Temperature**, and **Pressure**) and four data points (one for each location). This means that  $IMax=4$  for each zone. We include a text record (discussed in [Section 4-3.3 "Text Record"](#)) to add a title to the plot. The plot shown in [Figure 4-6](#) can be produced from this file.

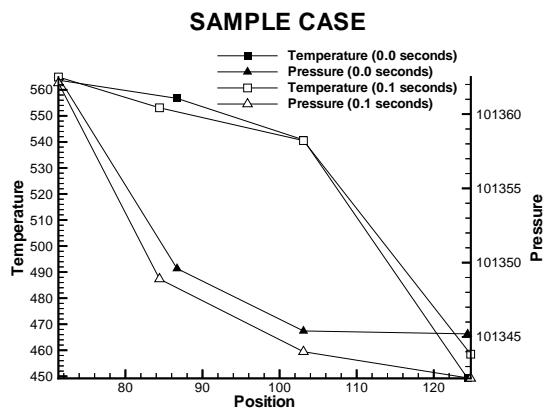

Figure 4-6. A multi-zone XY Line plot.

All of the values for the first variable (**Position**) at each data point are listed first, then all of the values for the second variable (**Temperature**) at each data point, and so forth.

```
TITLE = "Example: Multi-Zone XY Line Plot"
VARIABLES = "Position", "Temperature", "Pressure"
ZONE DATAPACKING=BLOCK, T="0.0 seconds", I=4
71.30 86.70 103.1 124.4
563.7 556.7 540.8 449.2
101362.5 101349.6 101345.4 101345.2
ZONE DATAPACKING=BLOCK, T="0.1 seconds", I=4
71.31 84.42 103.1 124.8
564.9 553.1 540.5 458.5
101362.1 101348.9 101344.0 101342.2
TEXT CS=FRAME, HU=POINT, X=16, Y=90, H=28, T="SAMPLE CASE"
```

### *Multi-Zone XY Line Plot with Variable Sharing Example*

If the data from the section above was taken at the same position for both times, variable sharing could reduce memory usage and file size. That file appears as:

```
TITLE = "Example: Multi-Zone XY Line Plot with Variable Sharing"
VARIABLES = "Position", "Temperature", "Pressure"
ZONE T="0.0 seconds", I=4
71.30 563.7 101362.5
86.70 556.7 101349.6
103.1 540.8 101345.4
124.4 449.2 101345.2
ZONE T="0.1 seconds", I=4
VARSHARELIST=( [1]=1) #share variable 1 from zone 1
564.9 101362.1
553.1 101348.9
540.5 101344.0
458.5 101342.2
TEXT CS=FRAME, HU=POINT, X=16, Y=90, H=28, T="SAMPLE VARIABLE SHARING CASE"
```

## Cell-Centered Data

An example of IJ-ordered data with cell-centered variables might include four variables (**x**, **y**, **Temperature**, **Pressure**), nine data points, and four cells where **Temperature** and **Pressure** are cell-centered.

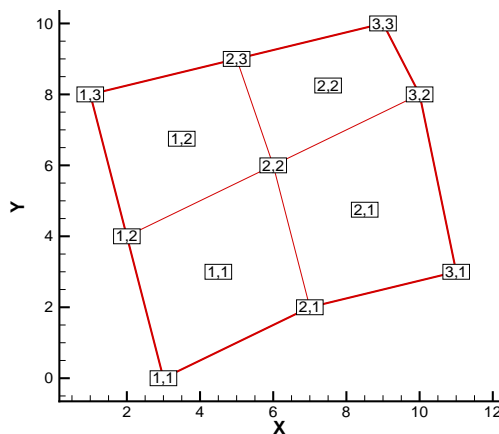

Figure 4-7. An IJ-ordered data set with cell-centered

```
VARIABLES = "X", "Y", "Temperature", "Pressure"
ZONE I=3, J=3, DATAPACKING=BLOCK, VARLOCATION=( [3,4]=CELLCENTERED)
3 7 11 2 6 10 1 5 9
0 2 3 4 6 8 8 9 10
0 2 1 3
45 60 35 70
```

The nodal variables of **x** and **y** are specified at all nine nodes, and the values of cell-centered variables are specified at the four cells  $[(I_{\text{Max}}-1) * (J_{\text{Max}}-1)]$ . Zones with cell-centered data must have **DATAPACKING=BLOCK**.

## Two-Dimensional Field Plots

A 2D field plot typically uses an IJ-ordered or finite element surface data set. However, any data structure can be viewed as a 2D field plot, by simply selecting “2D Cartesian” from the plot-type menu in the Sidebar.

An IJ-ordered data file has the basic structure shown below:

```
TITLE = "Example: Multi-Zone 2D Plot"
VARIABLES = "X", "Y", "Press", "Temp", "Vel"
ZONE T="BIG ZONE", I=3, J=3, DATAPACKING=POINT
1.0 2.0 100.0 50.0 1.0
1.0 3.0 95.0 50.0 1.00
1.0 4.0 90.0 50.0 0.90
```

```
2.0 2.0 91.0 40.0 0.90
2.0 3.0 85.0 40.0 0.90
2.0 4.0 80.0 40.0 0.80
3.0 2.0 89.0 35.0 0.85
3.0 3.0 83.0 35.0 0.80
3.0 4.0 79.0 35.0 0.80
ZONE T="SMALL ZONE", I=3, J=2, DATAPACKING=POINT
3.0 2.0 89.0 35.0 0.85
3.5 2.0 80.0 35.0 0.85
4.0 2.0 78.0 35.0 0.80
3.0 3.0 83.0 35.0 0.80
3.5 3.0 80.0 35.0 0.85
4.0 3.0 77.0 33.0 0.78
```

This data file has two zones and five variables, and is included with Tecplot 360 as the file `examples/dat/multzn2d.dat`. The first zone has nine data points arranged in a three-by-three grid (I=3, J=3). Each row of each zone represents one data point, where each column corresponds to the value of each variable for a given data point, i.e. X = 1.0, Y = 2.0, Press = 100.0, Temp = 50.0, and Vel=1.0 for data point one in zone one (Big Zone).

Similarly, the second zone (Small Zone) has six data points in a three-by-two mesh (I=3, J=2). Reading this data file yields the mesh plot shown in [Figure 4-13](#).

Refer to [Section “Two-Dimensional Field Plots”](#) on page 192 for an presentation of the same data in finite element format.

### *Three-Dimensional Field Plots*

IJK-ordered data sets have the general form shown below:

```
TITLE = "Example: Simple 3D Volume Data"
VARIABLES = "X", "Y", "Z", "Density"
ZONE I=3, J=4, K=3, DATAPACKING=POINT
1.0 2.0 1.1 2.21
2.0 2.1 1.2 5.05
3.0 2.2 1.1 7.16
1.0 3.0 1.2 3.66
...
```

The complete ASCII data file is included with Tecplot 360 as `simp3dpt.dat` (POINT format), and in block format as `simp3dbk.dat`. When you read either of these files into Tecplot 360, the plot will appear as shown in [Figure 4-8](#).

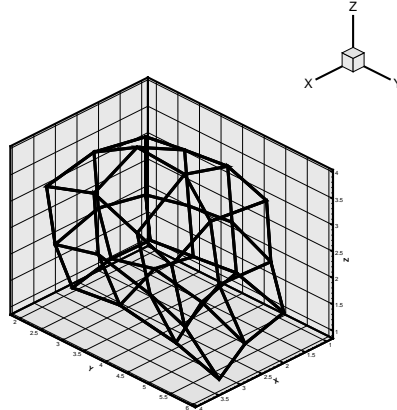

Figure 4-8. Plot of a 3D volume.

## 4 - 5 Finite Element Data

The zone header for a finite element zones lists the zone type, along with the number of nodes, elements and faces included in the zone. The following zone types are available for finite element data:

- **FELINESEG** - FE line segments zones contain one-dimensional finite element zones. For the line segment element type, each line of the connectivity list contains two node numbers that define a linear element.
- **FETRIANGLE** - FE triangular zones contain two-dimensional finite elements defined by three nodes. For the triangle element type, each line of the connectivity list contains three node numbers that define a triangular element.

- **FEQUADRILATERAL** - FE quadrilateral zones contain two-dimensional elements defined by four nodes. For the quadrilateral element type, each line of the connectivity list contains four node numbers that define a quadrilateral element.



If you need to mix quadrilateral and triangle elements, either use the polygonal zone type or use the quadrilateral element type with node numbers repeated to form triangles.

- **FEPOLYGON** - FE polygonal zones contain two-dimensional elements defined by a varying number of nodes (three or greater).
- **FETETRAHEDRON** - FE tetrahedral zones contain three-dimensional elements defined by four nodes.
- **FEBRICK** - FE brick zones contain three-dimensional elements defined by eight nodes. Tecplot 360 divides the eight nodes into two groups of four; nodes **N1<sub>M</sub>**, **N2<sub>M</sub>**, **N3<sub>M</sub>**, and **N4<sub>M</sub>** make up the first group, and **N5<sub>M</sub>**, **N6<sub>M</sub>**, **N7<sub>M</sub>**, and **N8<sub>M</sub>** make up the second group (where N# is the node number and M is the element number). Each node is connected to two nodes within its group and the node in the corresponding position in the other group. For example, **N1<sub>M</sub>** is connected to **N2<sub>M</sub>** and **N4<sub>M</sub>** in its own group, and to **N5<sub>M</sub>** in the second group.

To create elements with fewer than eight nodes, repeat nodes as necessary, keeping in mind the basic brick connectivity just described. [Figure 4-9](#) shows the basic brick connectivity. For example, to create a tetrahedron, you can set **N3<sub>M</sub>=N4<sub>M</sub>** and **N5<sub>M</sub>=N6<sub>M</sub>=N7<sub>M</sub>=N8<sub>M</sub>**. To create a quadrilateral-based pyramid, you can set **N5<sub>M</sub>=N6<sub>M</sub>=N7<sub>M</sub>=N8<sub>M</sub>**.

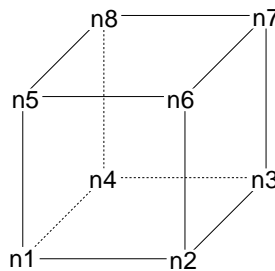

Figure 4-9. Basic brick connectivity.

- **FEPOLYHEDRAL** - FE polyhedral zones contain elements with a varying number of faces. Each element has at least four faces. The faces are defined by any number of nodes (with a minimum of three nodes in each face).

Refer to [Section 4- 3.2 “Zone Record”](#) for a complete list of the tokens included in the zone header.

After the zone header, the nodal data is listed. The nodal data contains the value of each variable for each node or element. Refer to [Section “Data”](#) on page 160 for details on arranging the data. The information following the nodal data is dependent upon the zone type.

For cell-based zone types (**FETRIANGLE**, **FEQUADILATERAL**, **FETETRAHEDRON**, and **FEBRICK**), the nodal data is followed by the connectivity section. The connectivity section describes arrangement of cells, relative to one another. There must be *numelements* lines in the second section; each line defines one element. The number of nodes per line in the connectivity list depends on the element type specified in the zone control line (**ZONETYPE** parameter). For example, **ZONETYPE=FETRIANGLE** has three numbers per line in the connectivity list. If nodes five, seven, and eight are connected, one line reads: **5 7 8**. Refer to [Section “Connectivity”](#) on page 163 for details. You may also define Face Neighbors following the connectivity list. Refer to [Section “Face Neighbor Connections List”](#) on page 163 for details. For face-based zone type (**FEPOLYGON** and **FEPOLYHEDRAL**), the data section ([Section “Data”](#) on page 160) is followed by the zone footer and facemap data sections. Refer to [Section “Facemap Data”](#) on page 165 for details.

## 4- 5.1 Variable and Connectivity List Sharing

The **VARSHARELIST** in the **ZONE** record allows you to share variables from specified previous zones. The **CONNECTIVITYSHAREZONE** parameter in the **ZONE** record allows you to share the connectivity list from a specified previous zone. The following is an example to illustrate these features. NOTE: Connectivity and/or face neighbors cannot be shared when the face neighbor mode is set to Global.

The table below shows Cartesian coordinates X and Y of six locations, and the pressure measured there at three different times ( $P_1$ ,  $P_2$ ,  $P_3$ ). The XY locations have been arranged into finite elements.

X	Y	P <sub>1</sub>	P <sub>2</sub>	P <sub>3</sub>
-1.0	0.0	100	110	120
0.0	0.0	125	135	145
1.0	0.0	150	160	180
-0.5	0.8	150	165	175
0.5	0.8	175	185	195
0.0	1.6	200	200	200

For this case, we want to set up three zones in the data file, one for each time measurement. Each zone has three variables: X, Y, and P. The zones are of the triangle element type, meaning that three nodes must be used to define each element. One way to set up this data file would be to list the complete set of values for X, Y, and P for each zone. Since the XY-coordinates are exactly the same for all three zones, a more compact data file can be made by using the **VARSHARELIST**. In the data file given below, the second and third zones have variable sharing lists that share the values of the

X- and Y-variables and the connectivity list from the first zone. As a result, the only values listed for the second and third zones are the pressure variable values. Note that the data could easily have been organized in a single zone with five variables. Since blank lines are ignored in the data file, you can embed them to improve readability. A plot of the data is shown in [Figure 4-10](#).

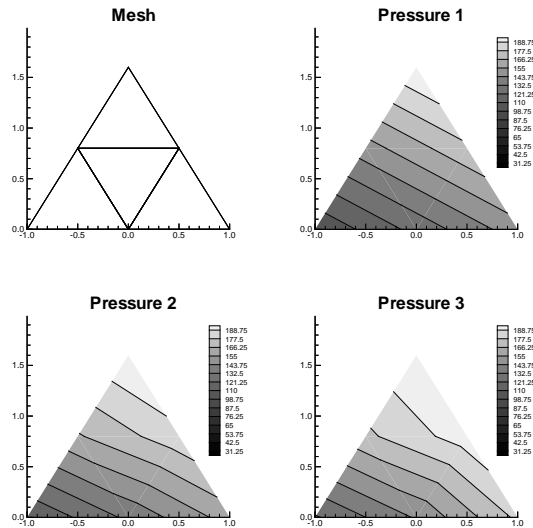

Figure 4-10. A plot of finite element zones.

```

TITLE = "Example: Variable and Connectivity List Sharing"
VARIABLES = "X", "Y", "P"
ZONE T="P 1", DATAPACKING=POINT, NODES=6, ELEMENTS=4, ZONETYPE=FETRIANGLE
-1.0 0.0 100
0.0 0.0 125
1.0 0.0 150
-0.5 0.8 150
0.5 0.8 175
0.0 1.6 200

1 2 4
2 5 4
3 5 2
5 6 4
ZONE T="P 2", DATAPACKING=POINT, NODES=6, ELEMENTS=4, ZONETYPE=FETRIANGLE,
VARSHARELIST = ([1, 2]=1), CONNECTIVITYSHAREZONE = 1
110 135 160 165 185 200

ZONE T="P 3", DATAPACKING=POINT, NODES=6, ELEMENTS=4, ZONETYPE=FETRIANGLE,
VARSHARELIST = ([1, 2]=1), CONNECTIVITYSHAREZONE = 1
120 145 180 175 195 200
    
```

## 4- 5.2 Finite Element Data Set Examples

Creating a finite element data set is generally more complicated than creating a similar-sized ordered data set<sup>1</sup>. In addition to specifying all the data points, you must also specify the connectivity list. Consider the data shown in [Table 4 - 2](#).

**Table 4 - 2: finite element Data**

Node	X	Y	P	T
A	0.0	1.0	100.0	1.6
B	1.0	1.0	150.0	1.5
C	3.0	1.0	300.0	2.0
D	0.0	0.0	50.0	1.0
E	1.0	0.0	100.0	1.4
F	3.0	0.0	200.0	2.2
G	4.0	0.0	400.0	3.0
H	2.0	2.0	280.0	1.9

You can create a **POINT** Tecplot 360 data file for this data set as follows (a 2D mesh plot of this data set is shown in [Figure 4-11](#)):

```

TITLE = "Example: 2D Finite Element Data"
VARIABLES = "X", "Y", "P", "T"
ZONE NODES=8, ELEMENTS=4, DATAPACKING=POINT, ZONETYPE=FEQUADRILATERAL
0.0 1.0 100.0 1.6
1.0 1.0 150.0 1.5
3.0 1.0 300.0 2.0
0.0 0.0 50.0 1.0
1.0 0.0 100.0 1.4
3.0 0.0 200.0 2.
4.0 0.0 400.0 3.0
2.0 2.0 280.0 1.9
1 2 5 4
2 3 6 5
6 7 3 3

```

1. Background information for FE data sets is provided in [Section 3- 2.2 "Indexing Cell-centered Ordered Data"](#) in the [User's Manual](#).

3 2 8 8

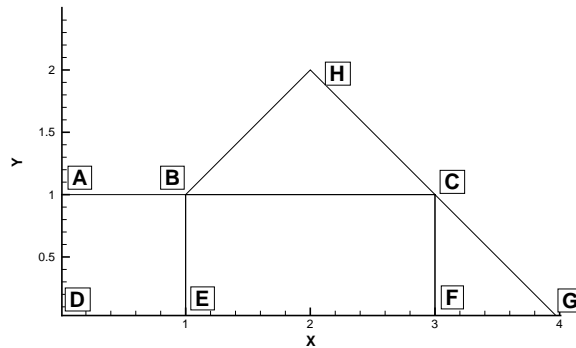

Figure 4-11. A mesh plot of 2D finite element data.

The **ZONE** record describes completely the form and format of the data set: there are eight nodes, indicated by the parameter **NODES=8**; four elements, indicated by the parameter **ELEMENTS=4**, and the elements are all quadrilaterals, as indicated by the parameter **ZONETYPE=FEQUADRILATERAL**.

The same data file can be written more compactly in **BLOCK** format as follows:

```

TITLE = "Example: 2D Finite Element Data"
VARIABLES = "X", "Y", "P", "T"
ZONE NODES=8, ELEMENTS=4, DATAPACKING=BLOCK, ZONETYPE=FEQUADRILATERAL
0.0 1.0 3.0 0.0 1.0 3.0 4.0 2.0
1.0 1.0 1.0 0.0 0.0 0.0 0.0 2.0
100.0 150.0 300.0 50.0 100.0 200.0 400.0 280.0
1.6 1.5 2.0 1.0 1.4 2.2 3.0 1.9
1 2 5 4
2 3 6 5
6 7 3 3
3 2 8 8
    
```

In **BLOCK** format, all values for a single variable are written in a single block. The length of the block is the number of data points in the zone. In **POINT** format, all variables for a single data point are written in a block, with the length of the block equal to the number of variables.

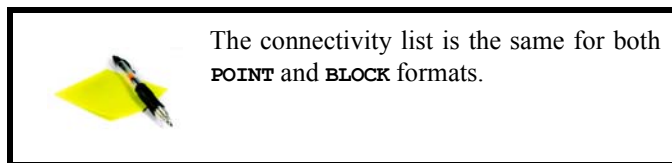

You can change the connectivity list to obtain a different mesh for the same data points. In the above example, substituting the following connectivity list yields the five-element mesh shown in

[Figure 4-12](#). (You must also change the **ELEMENTS** parameter in the zone control line to specify five elements.)

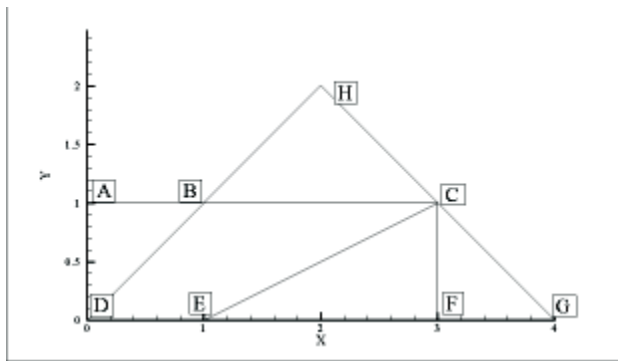

*Figure 4-12.* Finite element data of [Figure 4-11](#) with a different connectivity list

```
1 2 4 4
4 2 3 5
5 3 6 6
6 7 3 3
3 2 8 8
```

## Two-Dimensional Field Plots

A 2D finite element data file is shown below (included in your Tecplot 360 distribution as `examples/dat/2dfed.dat`):

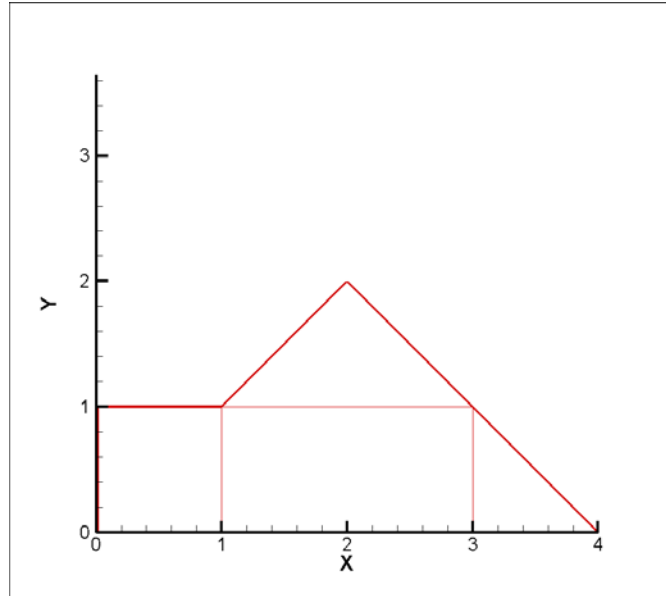

Figure 4-13. A 2D field plot.

```

TITLE = "Example: 2D Finite Element Data"
VARIABLES = "X", "Y", "P", "T"
ZONE NODES=8, ELEMENTS=4, DATAPACKING=POINT, ZONETYPE=FEQUADRILATERAL
0.0 1.0 75.0 1.6
1.0 1.0 100.0 1.5
3.0 1.0 300.0 2.0
0.0 0.0 50.0 1.0
1.0 0.0 100.0 1.4
3.0 0.0 200.0 2.2
4.0 0.0 400.0 3.0
2.0 2.0 280.0 1.9
1 2 5 4
2 3 6 5
6 7 3 3
3 2 8 8

```

The above finite element data file has eight nodes (the first eight rows of the zone) and four elements (the last four rows of the zone). Each row in the node matrix represents a given node. Each column in the row matrix corresponds to the value of each variable at a given node. The order of the variables definition correlates to the order the variables are named in the data set, i.e. for node one,  $X = 0.0$ ,  $Y = 1.0$ ,  $P = 75.0$  and  $T = 1.6$ . The element matrix defines the connectivity of the nodes, i.e. element one is composed of nodes one, two, five and four.

Please refer to [Chapter 3 “Data Structure”](#) in the [User’s Manual](#) for information on ordered and FE data sets.

### *Triangle Data in BLOCK Format Example*

An example of triangle element type finite element data is listed below. There are two variables ( $x$ ,  $y$ ) and five data points. This data set is plotted in [Figure 4-14](#). Each data point is labeled with its node number.

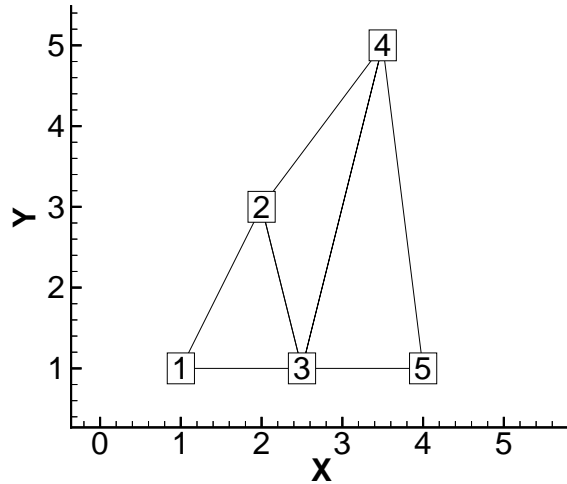

Figure 4-14. A finite element triangle data set.

In this example, each column of the data section corresponds to a node and each row to a variable. Each row of the connectivity list corresponds to a triangular element and each column specifies a node number.

```
VARIABLES = "X", "Y"
ZONE NODES=5, ELEMENTS=3, DATAPACKING=BLOCK, ZONETYPE=FETRIANGLE
1.0 2.0 2.5 3.5 4.0
1.0 3.0 1.0 5.0 1.0
1 2 3
3 2 4
3 5 4
```

### FORTRAN Code

This FORTRAN code creates triangle element type finite element data in **BLOCK** format:

```
INTEGER VAR
.
.
WRITE (*,*) 'ZONE DATAPACKING=BLOCK, ZONETYPE=FETRIANGLE,NODES=',NNODES,
```

```

& ,ELEMENTS= ,NELEM
DO 1 VAR=1,NUMVAR
DO 1 NODES=1,NNODES
  WRITE (*,*) VARRAY (VAR,NODES)
1 CONTINUE
DO 2 M=1,NELEM
DO 2 L=1,3
  WRITE (*,*) NDCNCT (M,L)
2 CONTINUE
  
```

### *Finite Element Zone Node Variable Parameters Example*

The node variable parameter allows setting of the connectivity to match the value of the selected node variable. In the example below, the files appear to be identical in Tecplot 360, although the connectivity list has changed to reflect the values of the node order. Notice that the index value of the nodes is not changed by the node variable value.

The original data set:

```

TITLE      = "Data with original node ordering"
VARIABLES = "X" "Y"
ZONE T="Triangulation"
NODES=6, ELEMENTS=5,DATAPACKING=POINT, ZONETYPE=FETRIANGLE
DT=(SINGLE SINGLE)
2.00E+000 3.00E+000
2.20E+000 3.10E+000
3.10E+000 4.20E+000
2.80E+000 3.50E+000
2.40E+000 2.10E+000
4.30E+000 3.20E+000
1 2 5
6 4 3
5 4 6
2 3 4
5 2 4
  
```

The data set with the nodes re-ordered for connectivity:

```

TITLE      = "Data with modified node ordering"
VARIABLES = "X" "Y" "Node-Order"
ZONE T="Triangulation"
NODES=6, NV = 3, ELEMENTS=5,DATAPACKING=POINT, ZONETYPE=FETRIANGLE
DT=(SINGLE SINGLE)
2.00E+000 3.00E+000 5
2.20E+000 3.10E+000 4
3.10E+000 4.20E+000 1
2.80E+000 3.50E+000 2
2.40E+000 2.10E+000 6
4.30E+000 3.20E+000 3
5 4 6
3 2 1
6 2 3
4 1 2
6 4 2
  
```

### *FE surface data*

Finite element surface data specify node locations in three dimensions. Consider the data in [Table 4 -3](#). Locations are listed for eleven nodes, each having only the three spatial variables X, Y, and Z. We would like to create an finite element surface zone with this data set, where some of the elements are triangles and some are quadrilaterals. All the elements could be organized into one zone of element type Quadrilateral. However, as an illustration of creating 3D surface data, create three zones: one triangular, one quadrilateral, and one a mixture (using quadrilaterals with repeated nodes for the triangles).

**Table 4 - 3: Data set with eleven nodes and three variables.**

X	Y	Z
0.0	0.0	1.0
0.0	0.0	-2.0
1.0	0.0	-2.0
1.0	1.0	0.0
1.0	1.0	-1.0
1.0	-1.0	0.0
1.0	-1.0	-1.0
-1.0	1.0	0.0
-1.0	1.0	-1.0
-1.0	-1.0	0.0
-1.0	-1.0	-1.0

A Tecplot 360 data file for the data in [Table 4 - 3](#) is shown below in `POINT` format and plotted in [Figure 4-15](#):

```
TITLE = "Example: 3D FE-SURFACE ZONES"
VARIABLES = "X", "Y", "Z"
ZONE T="TRIANGLES", NODES=5, ELEMENTS=4, DATAPACKING=POINT,
ZONETYPE=FETRIANGLE
0.0 0.0 1.0
-1.0 -1.0 0.0
-1.0 1.0 0.0
1.0 1.0 0.0
1.0 -1.0 0.0
1 2 3
1 3 4
1 4 5
1 5 2
```

```

ZONE T="PURE-QUADS", NODES=8, ELEMENTS=4, DATAPACKING=POINT,
  ZONETYPE=FEQUADRILATERAL
-1.0 -1.0 0.0
-1.0 1.0 0.0
 1.0 1.0 0.0
 1.0 -1.0 0.0
-1.0 -1.0 -1.0
-1.0 1.0 -1.0
 1.0 1.0 -1.0
 1.0 -1.0 -1.0
 1 5 6 2
 2 6 7 3
 3 7 8 4
 4 8 5 1
ZONE T="MIXED", NODES=6, ELEMENTS=4, DATAPACKING=POINT,
  ZONETYPE=FEQUADRILATERAL
-1.0 -1.0 -1.0
-1.0 1.0 -1.0
 1.0 1.0 -1.0
 1.0 -1.0 -1.0
 0.0 0.0 -2.0
 1.0 0.0 -2.0
 1 5 2 2
 2 5 6 3
 3 4 6 6
 4 1 5 6

```

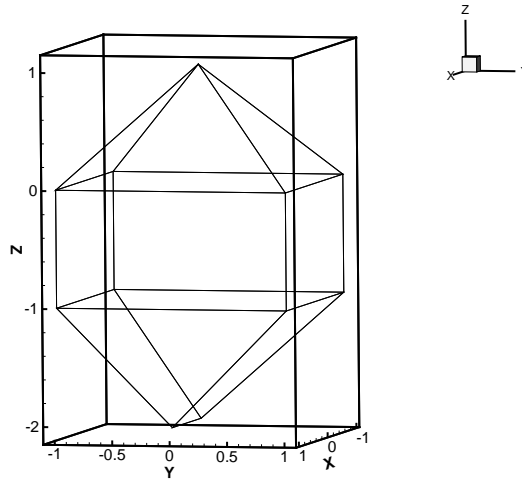

Figure 4-15. Three-dimensional mesh plot of finite element surface data.

## ***FE Volume Data Files***

Finite element volume data in Tecplot 360 is constructed from either tetrahedra having four nodes or bricks having eight nodes. Bricks are more flexible, because they can be used (through the use of repeated nodes in the connectivity list) to construct elements with fewer than eight nodes and combine those elements with bricks in a single zone.

### ***Finite Element Volume - Brick Data Set***

As a simple example of finite element volume brick data, consider the data in [Table 4 - 4](#). The data can be divided into five brick elements, each of which is defined by eight nodes.

**Table 4 - 4: Finite Element Volume - Brick Data Set. Data with 14 nodes and four variables.**

<b>X</b>	<b>Y</b>	<b>Z</b>	<b>Temperature</b>
0.0	0.0	0.0	9.5
1.0	1.0	0.0	14.5
1.0	0.0	0.0	15.0
1.0	1.0	1.0	16.0
1.0	0.0	1.0	15.5
2.0	2.0	0.0	17.0
2.0	1.0	0.0	17.0
2.0	0.0	0.0	17.5
2.0	2.0	1.0	18.5
2.0	1.0	1.0	20.0
2.0	0.0	1.0	17.5
2.0	2.0	2.0	18.0
2.0	1.0	2.0	17.5
2.0	0.0	2.0	16.5

In each element's connectivity list, Tecplot 360 draws connections from each node to three other nodes. You can think of the first four nodes in the element as the "bottom" layer of the brick, and the second four nodes as the "top." Within the bottom or top layer, nodes are connected cyclically (1-2-3-4-1; 5-6-7-8-5); the layers are connected by connecting corresponding nodes (1-5; 2-6; 3-7; 4-8). [Figure 4-9](#) illustrates this basic connectivity. When you are creating your own connectivity lists for brick elements, you must keep this basic connectivity in mind, particularly when using

duplicate nodes to create pyramids and wedges. Tecplot 360 lets you create elements that violate this basic connectivity, but the result will probably not be what you want.

The data file in **POINT** format is included in your distribution (*examples/dat/febrfep.dat*) and is shown below:

```
TITLE = "Example: FE-Volume Brick Data"
VARIABLES = "X", "Y", "Z", "Temperature"
ZONE NODES=14, ELEMENTS=5, DATAPACKING=POINT, ZONETYPE=FEBRICK
0.0 0.0 0.0 9.5
1.0 1.0 0.0 14.5
1.0 0.0 0.0 15.0
1.0 1.0 1.0 16.0
1.0 0.0 1.0 15.5
2.0 2.0 0.0 17.0
2.0 1.0 0.0 17.0
2.0 0.0 0.0 17.5
2.0 2.0 1.0 18.5
2.0 1.0 1.0 20.0
2.0 0.0 1.0 17.5
2.0 2.0 2.0 18.0
2.0 1.0 2.0 17.5
2.0 0.0 2.0 16.5
1 1 1 1 2 4 5 3
2 4 5 3 7 10 11 8
4 4 5 5 10 13 14 11
4 4 4 4 9 12 13 10
2 2 4 4 7 6 9 10
```

The same data in **BLOCK** format is included in your distribution (*examples/dat/febrfeb.dat*) and is shown below:

```
TITLE = "Example: FE-Volume Brick Data"
VARIABLES = "X", "Y", "Z", "Temperature"
ZONE NODES=14, ELEMENTS=5, DATAPACKING=BLOCK, ZONETYPE=FEBRICK
0.0 1.0 1.0 1.0 1.0 2.0 2.0 2.0 2.0 2.0 2.0 2.0 2.0 2.0
0.0 1.0 0.0 1.0 0.0 2.0 1.0 0.0 2.0 1.0 0.0 2.0 1.0 0.0
0.0 0.0 0.0 1.0 1.0 0.0 0.0 0.0 1.0 1.0 1.0 2.0 2.0 2.0
9.5 14.5 15.0 16.0 15.5 17.0 17.0
17.5 18.5 20.0 17.5 18.0 17.5 16.5
1 1 1 1 2 4 5 3
2 4 5 3 7 10 11 8
4 4 5 5 10 13 14 11
4 4 4 4 9 12 13 102 2 4 4 7 6 9 10
```

[Figure 4-16](#) shows the resulting mesh plot from the data set listed in this section.

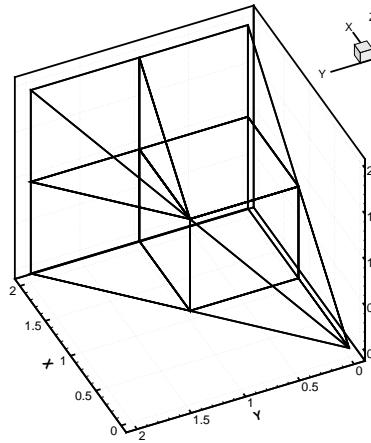

Figure 4-16. A finite element brick zone.

### ***Finite Element Volume - Tetrahedral Data Set***

As a simple example of a finite element volume data set using tetrahedral elements, consider the data in [Table 4 - 5](#). The data set consists of thirteen nodes, with seven variables. The nodes are to be connected to form twenty tetrahedral elements, each with four nodes.

**Table 4 - 5: Finite Element Volume - Tetrahedral data set with 13 nodes and seven variables.**

<b>X</b>	<b>Y</b>	<b>Z</b>	<b>C</b>	<b>U</b>	<b>V</b>	<b>W</b>
0	0	-95	-1	1	0	8
0	85	-42	0	-5	-3	9
81	26	-42	2	-22	80	8
50	-69	-42	-6	72	52	9
-50	-69	-42	14	67	-48	9
-81	26	-2	20	-30	-82	9
0	0	0	1	-2	-5	10
50	69	43	14	-68	48	11
81	-26	43	20	31	82	11

**Table 4 - 5: Finite Element Volume - Tetrahedral data set with 13 nodes and seven variables.**

X	Y	Z	C	U	V	W
0	-85	43	0	84	-3	10
-81	-26	43	2	21	-80	11
-50	69	43	-6	-71	-51	11
0	0	96	1	0	-1	12

The data file in **POINT** format for the data in [Table 4 - 5](#) is shown below, and plotted in [Figure 4-17](#):

```

TITLE = "Example: FE-Volume Tetrahedral Data"
VARIABLES = "X", "Y", "Z", "C", "U", "V", "W"
ZONE NODES=13, ELEMENTS=20, DATAPACKING=POINT, ZONETYPE=FETETRAHEDRON
0 0 -95 -1 1 0 8
0 85 -42 0 -85 -3 9
81 26 -42 2 -22 80 8
50 -69 -42 -6 72 52 9
-50 -69 -42 14 67 -48 9
-81 26 -42 20 -30 -82 9
0 0 0 1 -2 -5 10
50 69 43 14 -68 48 11
81 -26 43 20 31 82 11
0 -85 43 0 84 3 10
-81 -26 43 2 21 -80 11
-50 69 43 -6 -71 -51 11
0 0 96 1 0 -1 12
1 2 3 7
1 3 4 7
1 4 5 7
1 5 6 7
1 6 2 7
2 8 3 7
3 9 4 7
4 10 5 7
5 11 6 7
6 12 2 7
12 2 8 7
8 3 9 7
9 4 10 7
10 5 11 7
11 6 12 7
12 8 13 7
8 9 13 7
9 10 13 7
10 11 13 7
11 12 13 7
  
```

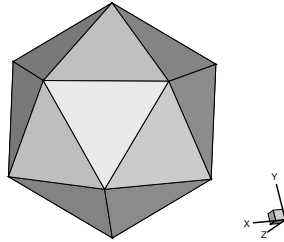
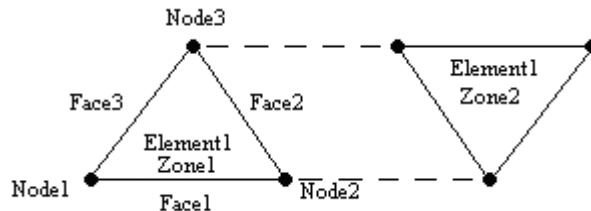

Figure 4-17. Finite element volume tetrahedral data.

This data file is included in your Tecplot 360 distribution's `examples/dat` directory as the file `fetetpt.dat`. A block format version of the same data is included as the file `fetetbk.dat`.

### *Polygonal - simple example*

A polygonal element in one zone connected to an element in another zone.



```

Zone
ZoneType=FEPolygon
Nodes=3
Faces=3
Elements=1
NumConnectedBoundaryFaces=2
TotalNumBoundaryConnections=1
...variable values in block format...

```

```

#face nodes
1 2
2 3
3 1
#left elements
1 1 1

```

```
#right elements (negative indicates boundary connections)
0 -1 0
#boundary connection counts
1
#boundary connection elements
1
#boundary connection zones
2
```

### *Polyhedral - complex example*

A single tetrahedron bounded on face two by zone two (elements 13 and 14) and on face three by zone three (element 11).

```
Zone
ZoneType=FEPolyhedron
Nodes=4
Faces=4
Elements=1
TotalNumFaceNodes=12
NumConnectedBoundaryFaces=2
TotalNumBoundaryConnections=3
...variable values in block format...
```

```
#node count per face
3 3 3 3
#face nodes
1 2 3
1 4 2
2 4 3
3 4 1
#left elements (negative indicates boundary connection)
0 -1 -2 0
#right elements
1 1 1 1
#boundary connection counts
2 1
#boundary connection elements
13 14 11
#boundary connection zones
2 2 3
```

## **4 - 6 ASCII Data File Conversion to Binary**

Although Tecplot 360 can read and write ASCII or binary data files, binary data files are more compact and are read into Tecplot 360 much more quickly. Your Tecplot 360 distribution includes Preplot, which converts ASCII to binary data files. You can also use Preplot to debug ASCII data files that Tecplot 360 cannot read.

## 4- 6.1 Preplot Options

To use Preplot, type the following command from the UNIX shell prompt, from a DOS prompt, or using the Run command on Windows platforms:

```
preplot infile [outfile] [options]
```

where *infile* is the name of the ASCII data file, *outfile* is an optional name for the binary data file created by Preplot, and *options* is a set of options from the standard set of Preplot options. If *outfile* is not specified, the binary data file has the same base name as the *infile* with a **.plt** extension. You may use a minus sign (“-”) in place of either the *infile* or *outfile* to specify standard input or standard output, respectively.

Any or all of **-iset**, **-jset**, and **-kset** can be set for each zone, but only one of each per zone.

For the standard set of preplot options, see [Section B - 4 “Preplot”](#) in the [User’s Manual](#).

## 4- 6.2 Preplot Examples

If you have an ASCII file named **dset.dat**, you can create a binary data file called **dset.plt** with the following Preplot command:

```
preplot dset.dat dset.plt
```

By default, Preplot looks for files with the **.dat** extension, and creates binary files with the **.plt** extension. Thus, either of the following commands is equivalent to the above command:

```
preplot dset  
preplot dset.dat
```

Preplot checks the input ASCII data file for errors such as illegal format, numbers too small or too large, the wrong number of values in a data block, and illegal finite element node numbers. If Preplot finds an error, it issues a message displaying the line and column where the error was first noticed. This is only an indication of where the error was *detected*; the actual error may be in the preceding columns or lines.

If Preplot encounters an error, you may want to set the debug option to get more information about the events leading up to the error:

```
preplot dset.dat -d
```

You can set the flag to **-d2**, or **-d3**, or **-d4**, and so forth, to obtain more detailed information.

In the following Preplot command line, the number of points that are written to the binary data file **dset.plt** is less than the number of points in the input file **dset.dat**:

```
preplot dset.dat -iset 3,6,34,2 -jset 3,1,21,1 -iset 4,4,44,5
```

For zone three, Preplot outputs data points with I-index starting at six and ending at 34, skipping every other one, and J-index starting at one and ending at 21. For zone four, Preplot outputs data points with the I-index starting at four, ending at 44, and skipping by five.

In the following Preplot command line, every other point in the I-, J-, and K-directions is written to the binary data file:

```
preplot dset.dat -iset ,,,2 -jset ,,,2 -kset ,,,2
```

The *zone*, *start*, and *end* parameters are not specified, so all zones are used, starting with index one, and ending with the maximum index. The overall effect is to reduce the number of data points by a factor of about eight.

The following terms are used throughout the *Data Format Guide* and are included here for your reference.

<b>2D</b>	<i>Plotting in two dimensions. Line plots of one or more variables (XY and Polar Line plots) are not considered 2D.</i>
<b>2D Cartesian Plot</b>	<i>A plot of some variable by location on a single plane using two axes.</i>
<b>3D</b>	<i>Plotting in three dimensions. Three-dimensional plotting can be subdivided into 3D surface and 3D volume.</i>
<b>3D Cartesian Plot</b>	<i>A plot displaying a 3D scattering of points, surfaces, or volumes using three orthogonal axes.</i>
<b>3D Surface</b>	<i>Three-dimensional plotting confined to a surface. For example, the surface of a wing.</i>
<b>3D Volume</b>	<i>Three-dimensional plotting of data that includes interior data points of a volume, as well as those on the surface. For example, the vector field around a wing.</i>
<b>Active Zone</b>	<i>A zone that is displayed in the current plot, as determined in the Zone Style dialog.</i>
<b>ASCII Data File</b>	<i>A data file composed of human-readable statements and numbers using ASCII characters.</i>
<b>Auxiliary Data</b>	<i>Metadata attached to zones, data sets, and frames.</i>
<b>Binary Data File</b>	<i>A data file composed of machine-readable data. This type of file is created by converting ASCII data files with Preplot, or by directly creating them from an application.</i>

<b>Block</b>	<i>A data file format in which the data is listed by variable. All the point values of the first variable are listed first, then all the point values of the second variable, and so forth.</i>
<b>Boundary Cell Faces</b>	<i>A set of un-blanked cell faces in a 3D volume zone which have only one neighboring volume cell. In contrast, interior cell faces have two neighboring volume cells, one on either side, which share the face. For an IJK-ordered zone the boundary cell faces are on the exterior of the zone. That is, the first and last I-planes, the first and last J-planes, and the first and last K-planes. For a finite element 3D volume zone, boundary cell faces are on the exterior of the zone and the surface of any voids within the zone.</i>
<b>Brick</b>	<i>An element type of finite element volume data composed of eight node points arranged in a hexahedron-like format. This element type is used in 3D volume plotting.</i>
<b>Cell</b>	<i>Either an element of finite element data, or the space contained by one increment of each index of IJ- or IJK-ordered data.</i>
<b>Cell-Centered Values</b>	<i>Values located at the center of the cell (assumed to be the centroid).</i>
<b>Connectivity List</b>	<i>The portion of a finite element data file which defines the elements or cells by listing the relationships between points. The number of points per cell is determined by the element type.</i>
<b>Custom Labels</b>	<i>Text strings contained within a data file or text geometry file which define labels for your axes or contour table. You may select Custom Labels anywhere you can choose a number format, the result is the text strings in place of numbers. The maximum length of a custom label is 1024 characters.</i>
<b>Data File</b>	<i>A file that contains data used for plotting in Tecplot.</i>
<b>Data Format</b>	<i>The type of zone data as specified by the format parameter in a Tecplot data file, such as: BLOCK or POINT.</i>
<b>Data Loader</b>	<i>A Tecplot add-on which allows you to read non-Tecplot data files.</i>
<b>Data Point</b>	<i>An XYZ-point at which field variables are defined.</i>

<b>Data Set</b>	<i>A set of one or more zones. A data set may be plotted in one or more frames. However, a single frame may only plot one data set. A data set may be created by loading one or more data files.</i>
<b>Element Type</b>	<i>The form of individual elements in a finite element zone. There are four types of cell-based finite element zones: Triangle and Quadrilateral (finite element surface types), and Tetrahedron and Brick (finite element volume types). For cell-based finite elements, the element type of a zone determines the number of nodes per element and their orientation within an element. There are two types of face-based finite element zones: polygonal (2D) and polyhedral (3D). For face-based elements, the number of nodes per element is variable.</i>
<b>FE</b>	<i>An abbreviation for finite element, a common means of arranging data for calculations. (Often referred to as “unordered” or “unstructured”.)</i>
<b>FE Surface</b>	<i>A finite element zone of the element type Triangle, Quadrilateral, Polygon. These zones are used for 2D and 3D surface plots.</i>
<b>FE Volume</b>	<i>A finite element zone of the element type Tetrahedron, Brick, Polyhedron. These zones are used for 3D volume plots.</i>
<b>Field Map</b>	<i>A collection of zones for 2D and 3D field plots. A common style can be easily applied to all zones in the selection.</i>
<b>Field Plot</b>	<i>Includes 2D Cartesian and 3D Cartesian plot types. Generally used to display the spacial relationship of data. Mesh, Contour, Vector, Scatter and Shade are all considered field plots. XY and Polar Line plots and the Sketch plot type are not field plots.</i>
<b>Finite Element</b>	<i>A type of data point ordering. Data is arranged by listing the data points (called nodes), and then listing their relationships (called elements). The element type of the zone determines the number of nodes which are contained in each element, as well as the exact relationship of nodes within an element. There are several different element types supported by Tecplot: <a href="#">Triangle</a>, <a href="#">Quadrilateral</a>, <a href="#">Tetrahedron</a>, <a href="#">Brick</a>, <a href="#">Polygonal</a> and <a href="#">Polyhedral</a>. See also: <a href="#">Connectivity List</a> and <a href="#">Node</a></i>

<b>I-Ordered</b>	<i>A type of data point ordering where each point is listed one at a time (that is, by one index). Used mainly in XY-plots. In 2D or 3D, this type of data point ordering is sometimes called irregular, and is only useful for scatter plots, or for interpolating or triangulating into 2D, 3D surface, or 3D volume zones. (This type of data can also be used for 2D or 3D vector plots if streamtraces are not required.)</i>
<b>IJ-Ordered</b>	<i>A type of data point ordering where the points are arranged in a 2D array used for 2D and 3D surface plotting.</i>
<b>IJK-Blanking</b>	<i>A feature to include or exclude portions of an IJK-ordered zone based on index ranges.</i>
<b>IJK-Ordered</b>	<i>A type of data ordering where the points are arranged in a 3D array. Used for 3D volume plotting as well as 2D and 3D surface plotting.</i>
<b>I-Plane</b>	<i>In an ordered zone, the connected surface of all points with a constant I-index. In reality, I-planes may be cylinders, spheres, or any other shape.</i>
<b>Irregular Data</b>	<i>Points which have no order, or at least no order which can be easily converted to IJ- or IJK-ordering.</i>
<b>J-Plane</b>	<i>In an ordered zone, the connected surface of all points with a constant J-index. In reality, J-planes may be cylinders, spheres, or any other shape.</i>
<b>K-Plane</b>	<i>In an IJK-ordered zone, the connected surface of all points with a constant K-index. In reality, K-planes may be cylinders, spheres, or any other shape.</i>
<b>Macro</b>	<i>A file containing a list of instructions, called macro commands, which can duplicate virtually any action performed in Tecplot.</i>
<b>Macro Command</b>	<i>An instruction given to Tecplot in a macro file. Macro commands always start with a dollar sign and then an exclamation mark. For example, \$!Redraw refreshes a plot view.</i>
<b>Macro File</b>	<i>A file which contains a series of macro commands. Macro files are run from the command line, or through the Play option of the Macro sub-menu of the File menu.</i>
<b>Macro Function</b>	<i>A self-contained macro sub-routine.</i>

<b>Macro Variable</b>	<i>A holding place for numeric values in a macro file. There are two types of macro variables: user-defined (you set and retrieve the value), or internal (Tecplot sets the value and you may retrieve it).</i>
<b>No Neighboring Element</b>	<i>In polyhedral/polygonal fe data sets, the term “no neighboring element” refers to a face that does not have a neighboring element on either its right or left side.</i>
<b>Node</b>	<i>A point in finite element data.</i>
<b>Number Format</b>	<i>The style of numbers to display for a data or axis label; exponent, integer, float, and so forth.</i>
<b>Ordered Data</b>	<i>A type of data point organization which consists of a parameterized series of points. There are seven types of ordered data: I-, J-, K-, IJ-, JK-, IK-, and IJK-ordered. I-, IJ-, and IJK-ordered are the most common.</i>
<b>Polygonal</b>	<i>A 2D, face-based finite element type. The number of nodes per element is variable. That is, a single polygonal zone may contain triangular, quadrilateral, hexagonal, ..., etc. elements.</i>
<b>Polyhedral</b>	<i>A 3D, face-based finite element type. The number of nodes per element is variable. That is, a single polyhedral zone may contain tetrahedral and brick (and others) elements.</i>
<b>Point</b>	<i>A data file format for an I-, IJ-, or IJK-ordered zone in which the data is listed by point. All of the variable values for the first data point are listed first, then all the variable values for the second data point, and so forth.</i>
<b>Quadrilateral</b>	<i>An element type of finite element surface data which is composed of four node points arranged in a quadrilateral. Used in 2D and 3D surface plotting.</i>
<b>Sharing</b>	<i>Variable sharing allows a single storage location to be used by more than one party. For example, if the X-variable is shared between zones five and seven only one storage location is created. The storage is not freed by Tecplot until the number of parties accessing the data is reduced to zero. Variables and connectivity information may be shared.</i>
<b>Tetrahedron</b>	<i>An element type of finite element volume data which is composed of four node points arranged in a tetrahedron. (Used in 3D volume plotting.)</i>

<b>Triangle</b>	<i>An element type of finite element surface data which is composed of three node points arranged in a triangle. (Used in 2D and 3D surface plotting.)</i>
<b>Unordered or Unorganized Data</b>	<i>(See <a href="#">Irregular Data</a>.)</i>
<b>Zone</b>	<i>A subset of a data set which is assigned certain plot types. Zones may be activated (plotted) or deactivated (not plotted). Each zone has one type of data ordering: I-, IJ-, IJK-, or finite element. Zones are typically used to distinguish different portions of the data. For example, different calculations, experimental versus theoretical results, different time steps, or different types of objects, such as a wing surface versus a vector field around a wing.</i>
<b>Zone Layers</b>	<i>One way of displaying a 2D or 3D plot's data set. The plot is the sum of the active zone layers, which may include mesh, contour, vector, shade, scatter and edge.</i>

---

Refer to this section only if you wish to write your own functions. Otherwise, refer to [Section 3 - 1 "Getting Started"](#) for instructions for linking with the library provided by Tecplot, Inc.

```
/*
BINARY FILE FORMAT:
-----
The binary data file format (as produced by the preplot) is described below.

The binary datafile has two main sections.  A header section and a data
section.
```

```
+-----+
| HEADER SECTION |
+-----+
+-----+
| FLOAT32 |           EOHMARKER, value=357.0
+-----+
+-----+
| DATA SECTION |
+-----+
```

I. HEADER SECTION

The header section contains: the version number of the file, a title of the file, the names of the variables to be plotted, the descriptions of all zones to be read in and all text and geometry definitions.

i. Magic number, Version number

```
+-----+
| "#!TDV112"|           8 Bytes, exact characters "#!TDV112".
+-----+           Version number follows the "V" and
                        consumes the next 3 characters (for
                        example: "V75 ", "V101").
```

ii. Integer value of 1.

<pre> +-----+   INT32    +-----+ </pre>	<p>This is used to determine the byte order of the reader, relative to the writer.</p>
<p>iii. Title and variable names.</p>	
<pre> +-----+   INT32    +-----+ </pre>	<p>FileType: 0 = FULL, 1 = GRID, 2 = SOLUTION</p>
<pre> +-----+   INT32*N  +-----+ </pre>	<p>The TITLE. (See note 1.)</p>
<pre> +-----+   INT32    +-----+ </pre>	<p>Number of variables (NumVar) in the datafile.</p>
<pre> +-----+   INT32*N  +-----+ </pre>	<p>Variable names. N = L[1] + L[2] + ... L[NumVar] where: L[i] = length of the ith variable name + 1 (for the terminating 0 value). (See note 1.)</p>
<p>iv. Zones</p>	
<pre> +-----+   FLOAT32  +-----+ </pre>	<p>Zone marker. Value = 299.0</p>
<pre> +-----+   INT32*N  +-----+ </pre>	<p>Zone name. (See note 1.) N = (length of zone name) + 1.</p>
<pre> +-----+   INT32    +-----+ </pre>	<p>ParentZone: Zero-based zone number within this datafile to which this zone is a child.</p>
<pre> +-----+   INT32    +-----+ </pre>	<p>StrandID: -2 = pending strand ID for assignment by Tecplot -1 = static strand ID 0 &lt;= N &lt; 32700 valid strand ID</p>
<pre> +-----+   FLOAT64  +-----+ </pre>	<p>Solution time.</p>
<pre> +-----+   INT32    +-----+ </pre>	<p>Not used. Set to -1.</p>
<pre> +-----+   INT32    +-----+ </pre>	<p>ZoneType 0=ORDERED,           1=FELINESEG,           2=FETRIANGLE,       3=FEQUADRILATERAL,           4=FETETRAHEDRON,   5=FEBRICK,           6=FEPOLYGON,       7=FEPOLYHEDRON</p>
<pre> +-----+   INT32    +-----+ </pre>	<p>Specify Var Location. 0 = Don't specify, all data is located at the nodes. 1 = Specify</p>

---

---

```

if "specify var location" == 1
+-----+
| INT32*NV | Variable Location (only specify if above is 1).
+-----+   0 = Node, 1 = Cell Centered (See note 5.)
+-----+
| INT32    | Are raw local 1-to-1 face neighbors supplied?
+-----+   (0=FALSE 1=TRUE). These raw values are a
              compact form of the local 1-to-1 face neighbors.
              If supplied, Tecplot assumes that the face
              neighbors are fully specified. As such, it
              will not perform auto face neighbor assignment.
              This improves Tecplot's time to first plot.
              See the data section below for format details.
              ORDERED and FELINESEG zones must specify 0 for
              this value because raw face neighbors are not
              defined for these zone types. FEPOLYGON and
              FEPOLYHEDRON zones must specify 0 for this value
              since face neighbors are defined in the face map
              for these zone types.

+-----+
| INT32    | Number of miscellaneous user-defined face
+-----+   neighbor connections (value >= 0). This value
              is in addition to the face neighbors supplied
              in the raw section. FEPOLYGON and FEPOLYHEDRON
              zones must specify 0.

if "number of miscellaneous user-defined
    face neighbor connections" != 0
+-----+
| INT32    | User defined face neighbor mode
+-----+   (0=Local 1-to-1, 1=Local 1-to-many,
              2=Global 1-to-1, 3=Global 1-to-many)

if FE Zone:
+-----+
| INT32    | Indicates if the finite element face neighbors
+-----+   are completely specified by the miscellaneous
              face neighbors given: (0=NO, 1=YES). If yes,
              then Tecplot will not perform auto assignment
              of face neighbors otherwise all faces not
              specified are considered boundaries. If no,
              then Tecplot will perform auto-assignment of
              the face neighbors unless the raw face neighbor
              array was supplied. This option is not valid
              for ORDERED zones.

if Ordered Zone:
+-----+
| INT32*3  | IMax, JMax, KMax
+-----+

if FE Zone:
+-----+
| INT32    | NumPts
+-----+
if ZoneType is FEPOLYGON or FEPOLYHEDRON:
+-----+

```

---

```

| INT32 | NumFaces
+-----+
+-----+
| INT32 | Total number of face nodes. For FEPOLYGON
+-----+ zones, this is NumFaces*2.
+-----+
| INT32 | Total number of boundary faces. If any
+-----+ boundary faces exist, include one to represent
no neighboring element.
+-----+
| INT32 | Total number of boundary connections.
+-----+

```

```

+-----+
| INT32 | NumElements
+-----+
+-----+
| INT32*3 | ICellDim, JCellDim,
+-----+ KCellDim (for future use; set to zero)

```

For all zone types (repeat for each Auxiliary data name/value pair):

```

+-----+
| INT32 | 1=Auxiliary name/value pair to follow
+-----+ 0=No more Auxiliary name/value pairs.

```

If the above is 1, then supply the following:

```

+-----+
| INT32*N | name string (See note 1.)
+-----+
+-----+
| INT32 | Auxiliary Value Format
+-----+ (Currently only allow 0=AuxDataType_String)

```

```

+-----+
| INT32*N | Value string (See note 1.)
+-----+

```

v. Geometries

```

+-----+
| FLOAT32 | Geometry marker. Value = 399.0
+-----+
+-----+
| INT32 | Position CoordSys 0=Grid, 1=Frame,
+-----+ 2=FrameOffset(not used),
3= OldWindow(not used),
4=Grid3D
+-----+
+-----+
| INT32 | Scope 0=Global 1=Local
+-----+
+-----+
| INT32 | DrawOrder 0=After, 1=Before
+-----+
+-----+
| FLOAT64*3 | (X or Theta), (Y or R), (Z or dummy)
+-----+ i.e. the starting location

```

---

---

```

+-----+
| INT32  | Zone (0=all)
+-----+
+-----+
| INT32  | Color
+-----+
+-----+
| INT32  | FillColor
+-----+
+-----+
| INT32  | IsFilled (0=no 1=yes)
+-----+
+-----+
| INT32  | GeomType 0=Line, 1=Rectangle 2=Square,
+-----+           3=Circle, 4=ellipse
+-----+
| INT32  | LinePattern 0=Solid 1=Dashed 2=DashDot
+-----+           3=DashDotDot 4=Dotted
+-----+           5=LongDash
+-----+
| FLOAT64 | Pattern Length
+-----+
+-----+
| FLOAT64 | Line Thickness
+-----+
+-----+
| INT32   | NumEllipsePts
+-----+
+-----+
| INT32   | Arrowhead Style 0=Plain, 1=Filled, 2=Hollow
+-----+
+-----+
| INT32   | Arrowhead Attachment 0=None, 1=Beg, 2=End, 3=Both
+-----+
+-----+
| FLOAT64 | Arrowhead Size
+-----+
+-----+
| FLOAT64 | Arrowhead Angle
+-----+
+-----+
| IN32*N  | Macro Function Command (string: N = Length+1)
+-----+
+-----+
| INT32   | Polyline Field Data Type
+-----+           1=Float, 2=Double (GTYPE)
+-----+
| INT32   | Clipping (0=ClipToAxes, 1=ClipToViewport,
+-----+           2=ClipToFrame)

```

If the geometry type is line then:

```

+-----+
| INT32  | Number of polylines
+-----+
+-----+

```

```

| INT32      |      Number of points, line 1.
+-----+
+-----+
| GTYPE*N    |      X-block geometry points N=NumPts
+-----+
+-----+
| GTYPE*N    |      Y-block geometry points N=NumPts
+-----+
+-----+
| GTYPE*N    |      Z-block geometry points N=NumPts (Grid3D Only)
+-----+
.
.
.

```

If the geometry type is Rectangle then

```

+-----+
| GTYPE*2    |      X and Y offset for far corner of rectangle
+-----+

```

If the geometry type is Circle then

```

+-----+
| GTYPE      |      Radius
+-----+

```

If the geometry type is Square then

```

+-----+
| GTYPE      |      Width
+-----+

```

If the geometry type is Ellipse then

```

+-----+
| GTYPE*2    |      X and Y Radii
+-----+

```

vi. Text

```

+-----+
| FLOAT32    |      Text marker. Value=499.0
+-----+
+-----+
| INT32      |      Position CoordSys 0=Grid, 1=Frame,
+-----+                               2=FrameOffset(not used),
                                         3= OldWindow(not used),
                                         4=Grid3D(New to V10)
+-----+
| INT32      |      Scope 0=Global 1=Local
+-----+
+-----+
| FLOAT64*3  |      (X or Theta), (Y or R), (Z or dummy)
+-----+                               Starting Location
+-----+
| INT32      |      FontType
+-----+
+-----+
| INT32      |      Character Height Units 0=Grid, 1=Frame, 2=Point
+-----+

```

---

---

```

+-----+
+-----+
| FLOAT64 | Height of characters
+-----+
+-----+
| INT32 | Text Box type 0=NoBox 1=Hollow 2=Filled
+-----+
+-----+
| FLOAT64 | Text Box Margin
+-----+
+-----+
| FLOAT64 | Text Box Margin Linewidth
+-----+
+-----+
| INT32 | Text Box Outline Color
+-----+
+-----+
| INT32 | Text Box Fill Color
+-----+
+-----+
| FLOAT64 | Angle
+-----+
+-----+
| FLOAT64 | Line Spacing
+-----+
+-----+
| INT32 | Text Anchor. 0=left, 1=center,
                2=right, 3=midleft
                4=midcenter 5=midright,
                6=headleft 7=headcenter
                8=headright
+-----+

+-----+
| INT32 | Zone (0=all)
+-----+
+-----+
| INT32 | Color
+-----+
+-----+
| INT32*N | MacroFunctionCommand (string: N = Length + 1)
+-----+
+-----+
| INT32 | Clipping (0=ClipToAxes,
                1=ClipToViewport, 2=ClipToFrame)
+-----+
+-----+
| INT32*N | Text. N=Text Length+1
+-----+

```

vii. CustomLabel

```

+-----+
| FLOAT32 | CustomLabel Marker; F=599
+-----+
+-----+
| INT32 | Number of labels
+-----+
+-----+
| INT32*N | Text for label 1. (N=length of label + 1)
+-----+

```

---

```

+-----+           See note 1.
+-----+
| INT32*N |           Text for label 2. (N=length of label + 1)
+-----+           See note 1.
.
.
+-----+
| INT32*N |           Text for label NumLabels.
+-----+           (N=length of label + 1) See note 1.

```

viii. UserRec

```

+-----+
| FLOAT32 |           UserRec Marker; F=699
+-----+
+-----+
| INT32*N |           Text for UserRec. See note 1.
+-----+

```

ix. Dataset Auxiliary data.

```

+-----+
| FLOAT32 |           DataSetAux Marker; F=799.0
+-----+
+-----+
| INT32*N |           Text for Auxiliary "Name". See note 1.
+-----+
+-----+
| INT32   |           Auxiliary Value Format (Currently only
+-----+           allow 0=AuxDataType_String)
+-----+
| INT32*N |           Text for Auxiliary "Value". See note 1.
+-----+

```

x. Variable Auxiliary data.

```

+-----+
| FLOAT32 |           VarAux Marker; F=899.0
+-----+
+-----+
| INT32*N |           Variable number (zero based value)
+-----+
+-----+
| INT32*N |           Text for Auxiliary "Name". See note 1.
+-----+
+-----+
| INT32   |           Auxiliary Value Format (Currently only
+-----+           allow 0=AuxDataType_String)
+-----+
| INT32*N |           Text for Auxiliary "Value". See note 1.
+-----+

```

II. DATA SECTION (don't forget to separate the header from the data with an EOHMARKER). The data section contains all of the data associated with the zone definitions in the header.

i. For both ordered and fe zones:

```

+-----+
| FLOAT32 |           Zone marker Value = 299.0

```

---

```

+-----+
+-----+
| INT32*N | Variable data format, N=Total number of vars
+-----+      1=Float, 2=Double, 3=LongInt,
                  4=ShortInt, 5=Byte, 6=Bit

+-----+
| INT32 | Has passive variables: 0 = no, 1 = yes.
+-----+

if "has passive variables" != 0
+-----+
| INT32*NV | Is variable passive: 0 = no, 1 = yes
+-----+      (Omit entirely if "Has passive variables" is 0).

+-----+
| INT32 | Has variable sharing 0 = no, 1 = yes.
+-----+

if "has variable sharing" != 0
+-----+
| INT32*NV | Zero based zone number to share variable with
+-----+      (relative to this datafile). (-1 = no sharing).
                  (Omit entirely if "Has variable sharing" is 0).

+-----+
| INT32 | Zero based zone number to share connectivity
+-----+      list with (-1 = no sharing). FEPOLYGON and
                  FEPOLYHEDRON zones use this zone number to
                  share face map data.

```

Compressed list of min/max pairs for each non-shared and non-passive variable. For each non-shared and non-passive variable (as specified above):

```

+-----+
| FLOAT64 | Min value
+-----+
+-----+
| FLOAT64 | Max value
+-----+

+-----+
| xxxxxxxxxxx | Zone Data. Each variable is in data format as
+-----+      specified above.

```

ii. specific to ordered zones

```

if "zone number to share connectivity list with" == -1 &&
  "num of misc. user defined face neighbor connections" != 0
+-----+
| INT32*N | Face neighbor connections.
+-----+      N = (number of miscellaneous user defined
                  face neighbor connections) * P
                  (See note 5 below).

```

iii. specific to fe zones

```

if ZoneType is NOT FEPOLYGON or FEPOLYHEDRON:
  if "zone number to share connectivity lists with" == -1
+-----+
| INT32*N | Zone Connectivity Data N=L*JMax
+-----+      (see note 2 below ).

```

```

if "zone number to share connectivity lists with" == -1 &&
  "raw local 1-to-1 face neighbors are supplied"
+-----+
| INT32*N   |      Raw local 1-to-1 face neighbor array.
+-----+      N = (NumElements * NumFacesPerElement)
                (See note 3 below).

if "zone number to share connectivity lists with" == -1 &&
  "num of misc. user defined face neighbor connections" != 0
+-----+
| INT32*N   |      Face neighbor connections.
+-----+      N = (number of miscellaneous user defined
                face neighbor connections) * P
                (See note 4 below).

if ZoneType is FEPOLYGON or FEPOLYHEDRON:
  if "zone number to share face map data with" == -1
    +-----+
    | INT32*F   |      Face node offsets into the face nodes array
    +-----+      below. Does not exist for FEPOLYGON zones.
                    F = NumFaces+1.

    +-----+
    | INT32*FN  |      Face nodes array containing the node numbers
    +-----+      for all nodes in all faces.
                    FN = total number of face nodes.

    +-----+
    | INT32*F   |      Elements on the left side of all faces.
    +-----+      Boundary faces use a negative value which is
                    the negated offset into the face boundary
                    connection offsets array. A value of "-1"
                    indicates there is no left element.
                    F = NumFaces.

    +-----+
    | INT32*F   |      Elements on the right side of all faces. See
    +-----+      description of left elements above for more
                    details. F = NumFaces.

    if "total number of boundary faces" != 0
      +-----+
      | INT32*NBF |      Boundary face connection offsets into the
      +-----+      boundary face connection elements array and
                    the boundary face connection zones array.
                    The number of elements for a face (F) is
                    determined by offset[-o] - offset[-o-1]
                    where 'o' is the negative value from either
                    the left or right elements arrays above.
                    Offset[0] = 0. Offset[1] = 0 so that -1 as
                    the left or right element always indicates
                    no neighboring element. If the number of
                    elements is 0, then there is no neighboring
                    element.
                    NBF = total number of boundary faces + 1.

```

---

```

+-----+
| INT32*NBI | Boundary face connection elements. A value of
+-----+ "-1" indicates there is no element on part of
the face.
NBI = total number of boundary connections.

+-----+
| INT32*NBI | Boundary face connection zones. A value of
+-----+ "-1" indicates the current zone.
NBI = total number of boundary connections.

```

NOTES:

1. All character data is represented by INT32 values.

Example: The letter "A" has an ASCII value of 65. The WORD written to the data file for the letter "A" is then 65. In fortran this could be done by doing the following:

```

Integer*32 I
.
.
I = ICHAR('A');

WRITE(10) I

```

All character strings are null terminated  
(i.e. terminated by a zero value)

2. This represents JMax sets of adjacency zero based indices where each set contains L values and L is
  - 2 for LINESEGS
  - 3 for TRIANGLES
  - 4 for QUADRILATERALS
  - 4 for TETRAHEDRONS
  - 8 for BRICKS
3. The raw face neighbor array is dimensioned by (number of elements for the zone) times (the number of faces per element), where each member of the array holds the zero-based element neighbor of that face. A boundary face is one that has no neighboring element and is represented by a -1. Faces should only be neighbors if they logically share nodes and they should be reciprocal.

4. FaceNeighbor Mode	# values	Data
LocalOneToOne	3	cz, fz, cz
LocalOneToMany	nz+4	cz, fz, oz, nz, cz1, cz2, ..., czn
GlobalOneToOne	4	cz, fz, ZZ, CZ
GlobalOneToMany	2*nz+4	cz, fz, oz, nz, ZZ1, CZ1, ZZ2, CZ2, ..., ZZn, CZn

Where:

cz = cell in current zone (zero based)  
fz = face of cell in current zone (zero based)  
oz = face obscuration flag (only applies to one-to-many):  
    0 = face partially obscured  
    1 = face entirely obscured  
nz = number of cell or zone/cell associations  
    (only applies to one-to-many)  
ZZ = remote Zone (zero based)  
CZ = cell in remote zone (zero based)

cz,fz combinations must be unique and multiple entries are not allowed. Additionally, Tecplot assumes that with the one-to-one face neighbor modes, a supplied cell face is entirely obscured by its neighbor. With one-to-many, the obscuration flag must be supplied.

Face neighbors that are not supplied are run through Tecplot's auto face neighbor generator (FE only).

5. Cell centered variable (DATA SECTION)

To make reading of cell centered binary data efficient, Tecplot stores  $IMax \times JMax \times KMax$  numbers of cell centered values, where  $IMax$ ,  $JMax$ , and  $KMax$  represent the number of points in the I, J, and K directions. Therefore extra zero values (ghost values) are written to the data file for the slowest moving indices. For example, if your data's IJK dimensions are  $2 \times 3 \times 2$ , a cell-centered variable will have  $1 \times 2 \times 1$  (i.e.  $(I-1) \times (J-1) \times (K-1)$ ) significant values. However,  $2 \times 3 \times 2$  values must be written out because it must include the ghost values. Assume that the two significant cell-centered values are 1.5 and 12.5. The ghost values will be output with a zero value.

So if the zone was dimensioned  $2 \times 3 \times 2$  its cell centered variable would be represented as follows:

```
1.5  0.0  12.5  0.0  0.0  0.0  0.0  0.0  0.0  0.0  0.0  0.0
```

If the zone was dimensioned  $3 \times 2 \times 2$  its cell centered variable would be represented as follows:

```
1.5  12.5  0.0  0.0  0.0  0.0  0.0  0.0  0.0  0.0  0.0  0.0
```

and if the zone was dimensioned  $2 \times 2 \times 3$  its cell centered variable would be represented as follows:

```
1.5  0.0  0.0  0.0  12.5  0.0  0.0  0.0  0.0  0.0  0.0  0.0
```

For large variables the wasted space is less significant than it is for the small example above.

-----  
\*/

---

---



# Index

## A

Anchor

text position 169

ASCII Data

conversion to binary 151, 202

Custom Label Record 173

File Format 152–176

finite-element data 185–202

Geometry Record 170–173

ordered data 176–185

parameters 175

syntax 161

Text Record 167–170

Zone Record 154–167

ASCII format

syntax 151

Auxiliary Data 28, 159

variable auxiliary data 51, 175

zone auxiliary data 52

Axis Labels 43

## B

Binary Data

byte order 36

conversion from ASCII 151, 202

File Format 211–222

geometry creation 37

text record 47

user record 50

Binary files

debugging 24

writing to multiple 26, 35

writing to multiple, example 137

Block Data 160

Boundary Connection 59

Boundary Face 59

Boundary Map 167

Brick cells 186

Byte order 36

## C

Cell-centered 16

Cell-centered Data 31, 161

Cell-centered data 16

Connected Boundary Face 59

Connectivity list 163

cell-based finite elements 44

face-based finite elements 45

sharing 158, 167

Custom Label Record

ASCII data 173

binary data 43

## D

Data

cell-centered 16

FE Volume 16

nodal 16

Data Arrangement 31

Data conversion 151, 202

Data File Format

ASCII 152–176

binary 211–222

Data structure

finite-element 13

ordered data 12

Data Types 160

## E

EOF 32

Examples

ASCII

auxiliary data 174

finite-element 189–202

Geometry 172

ordered data 177–185

Text Record 170

Binary

Face Neighbors 64

geometry record 147

IJ-ordered 132

polygonal data 76

polyhedral zones 83, 103, 125

text record 144

## F

Face Neighbors 163, 166

data 33

example 64

mode 164

polyhedral zones 61

right-hand rule 61

scope 164

Face Numbering

cell-based finite elements 165

Facemap data 45, 165

- polyhedral zones 60
- FE data
  - see* Finite-element
- FE-line 15
- FE-surface 15
- FE-volume 16
- File
  - grid file 43
  - shared grid 43
  - solution file 43
- File Format
  - ASCII 152–176
  - Binary Data 211–222
- File Header 153
- Finite-element 13
  - FE-line 15
  - FE-surface 15
  - FE-volume 16
  - volume data 16
- Finite-element data
  - ASCII format 185–202
  - boundary map 167
  - bricks 186
  - connectivity list 44, 45, 163
  - face neighbors 33
  - face numbering (cell-based) 165
  - facemap 165
  - line segments 185
  - polygons 186
  - polyhedra 186
  - polyhedral format 45
  - quadrilaterals 186
  - tetrahedron 186
  - triangles 185
- Full file 43
- Function reference
  - TecIO library 28–58
- Function sequence
  - binary files 26

**G**

- Geometry Record
  - ASCII data 170–173
  - binary
    - example 147
    - syntax 37
  - data (ASCII) 172
  - origin positions 41
- Global one-to-many 164
- Global one-to-one 164

- Grid
  - sharing 43
- Grid File 43

**H**

- Header
  - file header 153
  - zone header 53

**I**

- Irregular data 176

**L**

- Labels, custom
  - binary data 43
- Legend text 43
- Line Segments 185
- Local one-to-many 164
- Local one-to-one 164

**M**

- Metadata, *see* Auxiliary Data

**N**

- Neighboring elements 166
- Nodal 16
- Nodal Data 31, 160
- Nodal data 16

**O**

- Ordered Data 176–185
  - Example (binary) 132
  - Examples
    - 2D Field Plot 183
    - 3D Field Plot 184
    - IJK-ordered 180
    - IJ-ordered 179
    - I-ordered 178
  - Examples (ASCII) 177–185
  - IJK-ordered data 177
  - IJ-ordered data 176
  - I-ordered data 176
  - one-dimensional 176
  - three-dimensional 177
  - two-dimensional 176
- Ordered data 12
- Origin positions
  - geometry 41

**P**

Parameters  
 ASCII data file 175  
 Pltview 24  
 Polygonal zones 186  
 Polyhedral cells 186  
 Polyhedral data  
 boundary connection 59  
 boundary face 59  
 Examples (binary)  
 multiple zones (2D) 103  
 multiple zones (3D) 83  
 polygon 76  
 polyhedral 125  
 face neighbors 61  
 facemap data 60  
 Preplot 151, 202

**Q**

Quadrilateral cells 186

**R**

Right-hand rule  
 face neighbors 61

**S**

Scatter Plots 176  
 Shared grid 43  
 Solution file 43  
 Syntax  
 ASCII format 151  
 TecIO functions 28–58

**T**

**TECAUXSTR112** 28  
**TECDAT112** 29  
**TECEND112** 32  
**TECFACE** 33  
**TECFIL** 35  
**TECFOREIGN** 36  
**TECGEO** 37  
 TecIO functions 28–58  
 TecIO library 23  
 deprecated functions 25  
 function calling sequence 26  
 function reference 28–58  
 linking with 26  
**TECLAB** 43  
**TECNOD** 44  
**TECPOLY** 45

**TECTXT** 47  
**TECUSR** 50  
**TECVAUXSTR** 51  
**TECZAUSTR** 52  
**TECZNE** 53  
 Tetrahedral cells 186  
 Text Anchor 169  
 Text Record  
 ASCII data 167–170  
 Binary Data 47  
 example 144  
 Text Anchor positions 169  
 Tick mark Labels 43  
 Triangular Cells 185  
 Triangulation 176

**U**

Unstructured Data 176  
 User record  
 binary data 50

**V**

Variable auxiliary data 51  
 Variable Location 158, 160–161  
 Variable location 16  
 Variable Sharing 158, 162, 187  
 Variables  
 location 16  
 ViewBinary 24

**X**

XY Plot  
 example 181  
 XY Plots 176

**Z**

Zone auxiliary data 52  
 Zone Footer 162  
 Zone header 53  
 Zone Record 154–167  
 Zone Type  
 finite-element zones 185  
 Zone Types 156, 176  
**FEBRICK** 186  
**FELINESEG** 185  
**FEPOLYGON** 186  
**FEPOLYHEDRAL** 186  
**FEQUADRILATERAL** 186  
**FETETRAHEDRON** 186  
**FETRIANGLE** 185

